

1. To field install the TA-GR3 grommet start with the work surface in application position, measure and mark the center of the grommet location you wish to place on the top with an "X". See Figure 1 below. All holes should be a minimum of 1.00" off the edge of work surfaces.

IMPORTANT

Before cutting the hole, ensure that the selected location will not interfere with legs, other support related hardware or accessories mounted underneath the table.

2. Utilizing a 3.00" diameter Hole-Saw, align the pilot bit with the center of the "X" marked on the top to identify the desired grommet location. See Figure 2 below.

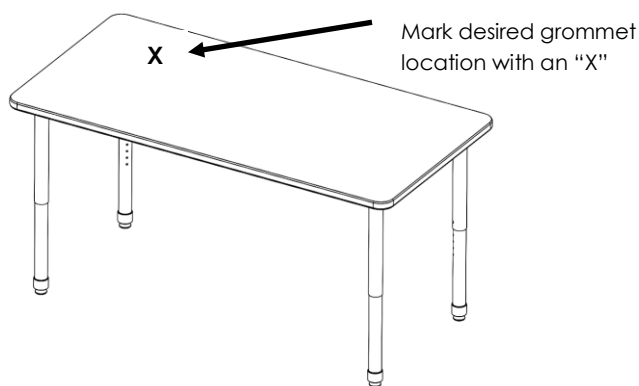

Figure 1

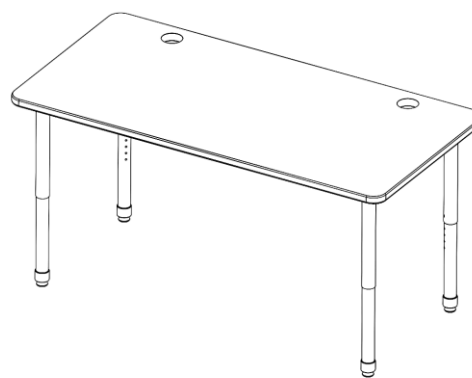

Figure 2

3. After drilling through the top with the 3" diameter Hole-Saw, remove all remaining sawdust from the top and inside of the newly cut grommet hole.
4. Install 3" Grommet by pushing into the hole until the flange of the grommet sleeve contacts the work surface completely. Snap in grommet cover.

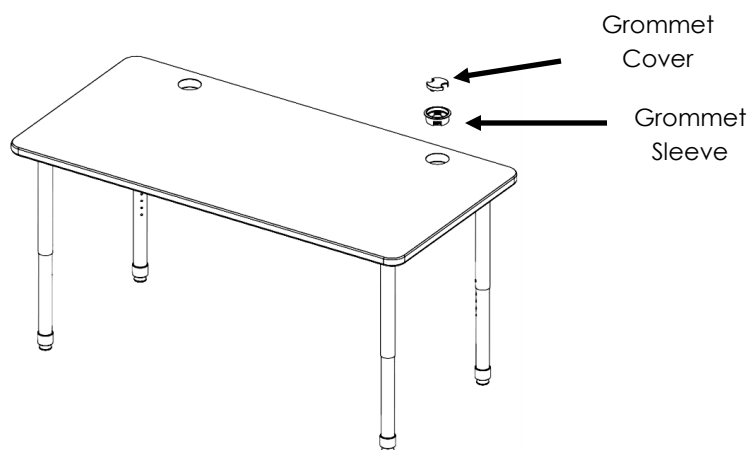

Figure 3