

## PARTS LIST

ITEM	DESCRIPTION	QTY.
A	TOP	1
B	LEFT UPPER RECEIVER	1
C	RIGHT UPPER RECEIVER	1
D	LOWER INSERT LEG	2
E	WIRE MGMT. PANEL	1
F	# 12 X 3/4" SCREW	18
G	# 10 X 11/16" SCREW	8
H	5/16 X 18NC X 1/2" SCREW	4

## TOOLS REQUIRED

PADDED WORK TABLE  
 # 3 PHIL. HD. BIT  
 # 2 PHIL. HD. BIT  
 1/4" ALLEN WRENCH  
 POWER DRIVER

## ASSEMBLY INSTRUCTIONS MODELS #CY03--#CY04--#CY05--#CY06

1. Compare all parts to parts list for identification and quantities. Read instructions before assembly.
2. Carefully remove contents of the carton.
3. Do not remove plastic from the top.
4. Carefully place the top (A) upside down (backer sheet up) on the shipping carton, or other padded surface, with grommet hole the closest to you.
5. Place an upper receiver (B) over the predrilled holes at the left side of the table. The three holes in the receiver should face to the back of the top. Attach the receiver to the tabletop using (6) silver screws (F). **DO NOT OVER TIGHTEN SCREWS!**
6. Place wire management panel (E) across the back edge of the table top (edge with grommet hole) allowing panel to rest against the back leg of the receiver that is attached to the table top, as shown in the diagram below.
7. Align the three holes on left side of the panel to the three holes in the receiver as shown in the diagram below. Attach the panel to the receiver using (3) black self-drilling screws (G).
8. Place remaining receiver (C) on tabletop at the right side of panel aligning the three holes of the panel with the three holes of the receiver. Attach the panel to the receiver using (3) black self-drilling screws (G).
9. Locate the two small tabs one on each end of the panel with the holes on the inside of the receiver legs. Attach the tabs to the receiver using (1) black self-drilling screw (G) each.
10. Locate the row of holes in the back edge of the panel over the predrilled holes on the top. Secure panel to the table top using the silver screws (F). Place screw in every hole. **DO NOT OVER TIGHTEN SCREWS!**
11. Attach the right receiver (C) to the table top using (6) silver screws (F). **DO NOT OVER TIGHTEN SCREWS!**
12. Slide the insert (D) down into the receiver (B/C) to desired height. Secure the insert with (2) black cap screws (H) one on each side of the receiver.

(See Reverse Side For The Completed View)

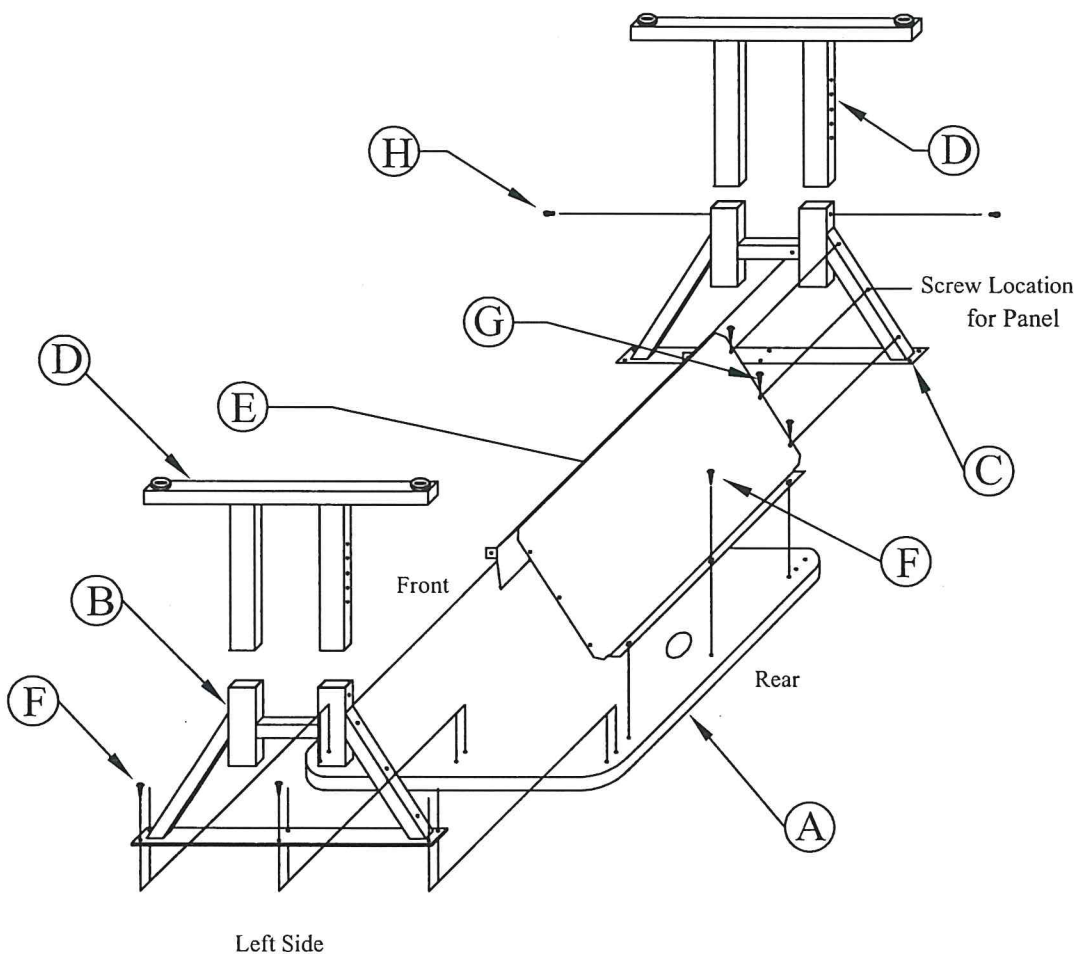

### Actual Size Screws

(F) # 3 PHIL HD SCREW

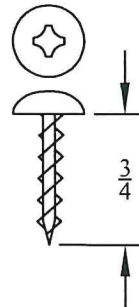

(G) # 2 PHIL HD SCREW

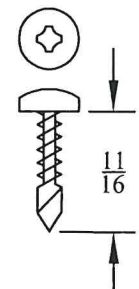

(H) CAP SCREW

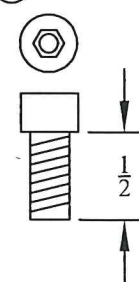

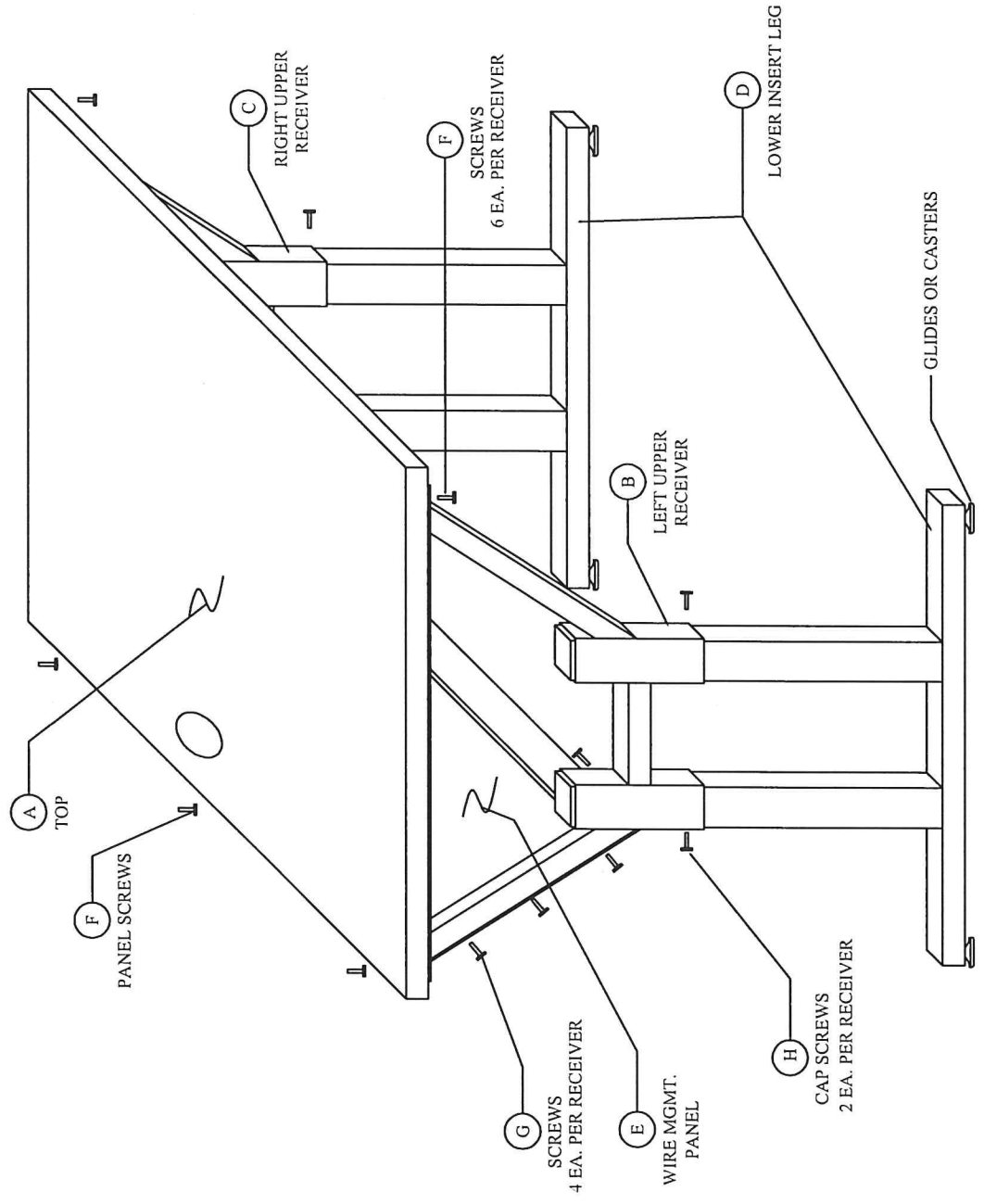
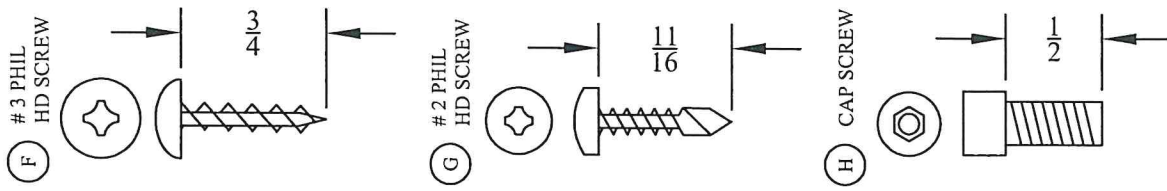

Note: Powerdriver is required for Item G.  
Fully Assembled Drawing of a CY Computer  
Table with Actual Sized Screw Drawings