

# Convertible Bench Table

## General Use and Operation

The Convertible Bench Table convert from a bench unit with backrest to a bench unit with table top by rotating the table top/backrest into the desired position. The table top/backrest shall automatically lock at both ends of the unit when used as a table unit. Folding Convertible Bench units shall have the following dimensions:

- > 8' overall width
- > 15.0" d top and 12.0" d benches. Overall open depth of 28.59"
- > 29.0" overall table height

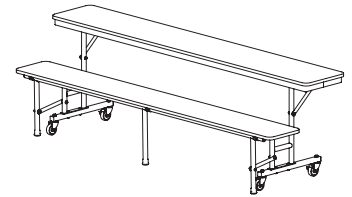

## Top & Bench | 3/4" Medium Density Fiberboard (MDF) Core with Permatuff Edge (N)

Top and bench is constructed of 3/4" thickness MDF with high-pressure laminate (HPL) top surface and a phenolic backer sheet for balanced construction (Markerboard laminate not available). Durable two part polyurethane epoxy resin is chemically bonded to the edge of the work surface to create a durable, impact resistant seamless edge. All tops and benches have a 1.5" corner radius.

## Frames

Tops are supported by a full perimeter 14-gauge 1.81" formed steel frame for long term durability and support. Tops are attached to the frame using #10 x 11/16 sheet metal screws. Bench is supported by two full width 14-gauge 1.05" diameter tubes. Front bench tube is fully welded to the bench support legs. Rear is a tube in tube attachment to the 1-1/4" T-support on the end pedestal leg assembly. Benches are attached to the frame using 16-gauge 2pc metal brackets and #10 x 11/16 sheet metal screws.

## Leg Assembly

Benches are supported by three (3) legs using 1-1/4" diameter, 14-gauge steel tubing that extends to the floor and are capped with neoprene rubber caps. End pedestal leg assemblies shall be of welded construction using 1-1/4" diameter 14-gauge steel tubing for all major upper structural support members. Each upper leg is attached to a 14-gauge x 1-1/4" square tube end pedestal foot using two (2) 3/8 -16 x 1-3/4" carriage bolts. Drive links are 1/4" x 1" flat steel stock with rounded edges. All units are standard with four (4) 3" diameter x 1.0" wide swivel type casters with a rated load capacity of 100 lbs per caster. Casters are factory installed, two (2) casters shall be locking. All units shall include one (1) standard rubber pivoting coupling device with integrated T-handle used to secure two units together. All metal components shall be powder coated except the end pedestal foot which shall be chrome plated.

## Compliance

- > Tested to applicable ANSI/BIFMA Furniture Standards
- > Complies with Consumer Products Safety Improvement Act (CPSIA) of 2008
- > Certified Indoor Advantage™ Gold. Indoor air quality certified to SCS-EC10.3-2014 V3.0. Registration #SCS-IAQ-03678



Artcobell's practice of continuous improvement in design & engineering requires that materials & methods be subject to change without prior notice.

T.S.T (2/6/2019) Artcobell Specifications

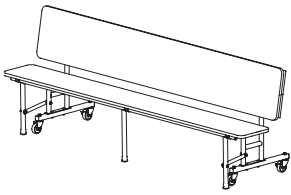

# Convertible Bench Table

## Single Unit | Open Table Position

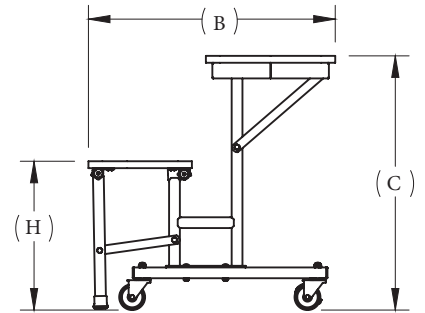
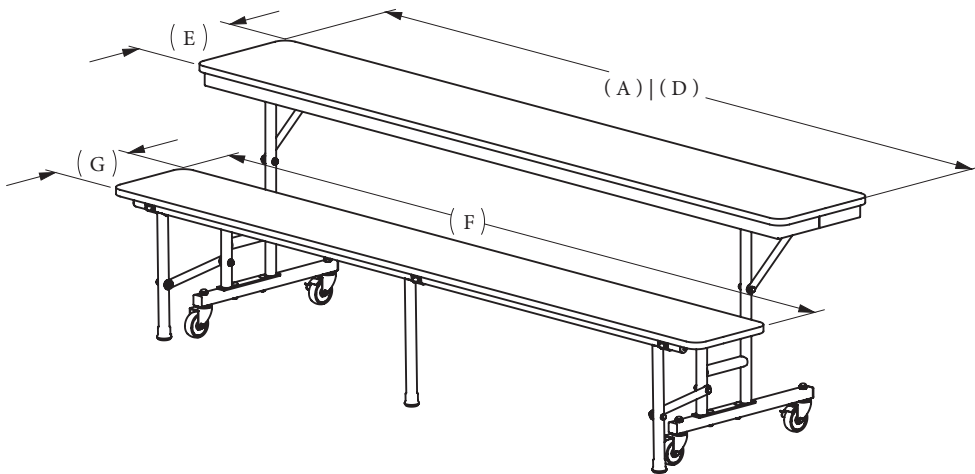

MODEL	OVERALL			TOP		BENCH		
	WIDTH" (A)	DEPTH" (B)	HEIGHT" (C)	WIDTH" (D)	DEPTH" (E)	WIDTH" (F)	DEPTH" (G)	HEIGHT" (H)
ABC89PN	96.0"	28.59"	29.0"	96.0"	15.0"	96.0"	12.0"	17.0"

artcobell

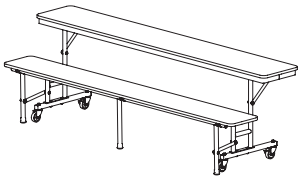

# Convertible Bench Table

## Single Unit | Open Bench Position

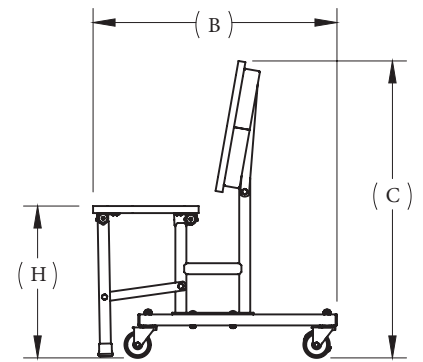
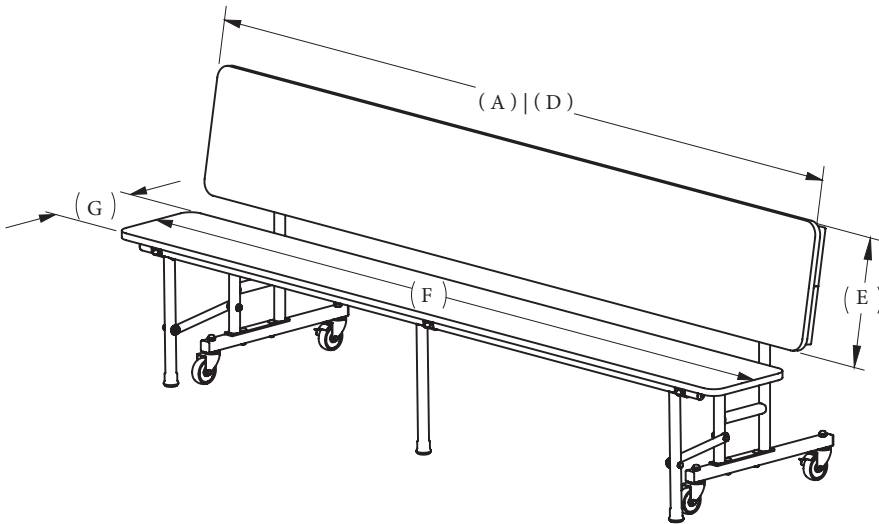

MODEL	OVERALL			TOP		BENCH		
	WIDTH" (A)	DEPTH" (B)	HEIGHT" (C)	WIDTH" (D)	DEPTH" (E)	WIDTH" (F)	DEPTH" (G)	HEIGHT" (H)
ABC89PN	96.0"	27.69"	33.71"	96.0"	15.0"	96.0"	12.0"	17.0"

artcobell

# Convertible Bench Table

## Single Unit | Folded Storage Position

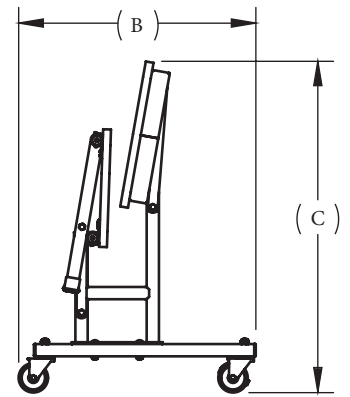
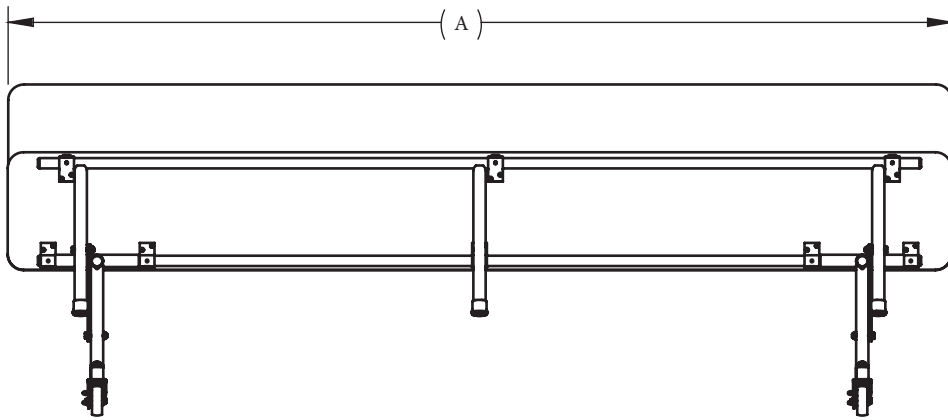
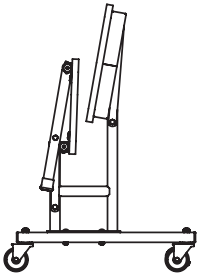

MODEL	OVERALL		
	WIDTH" (A)	DEPTH" (B)	HEIGHT" (C)
ABC89PN	96.0"	24.12"	33.71"

artcobell

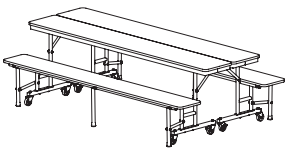

# Convertible Bench Table

## Two Units | Coupled Together

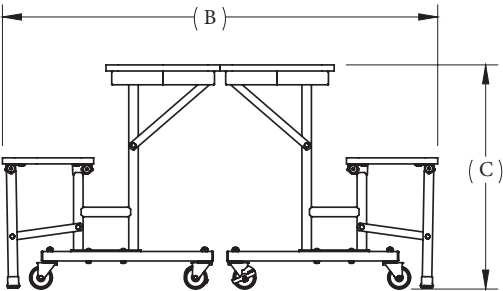
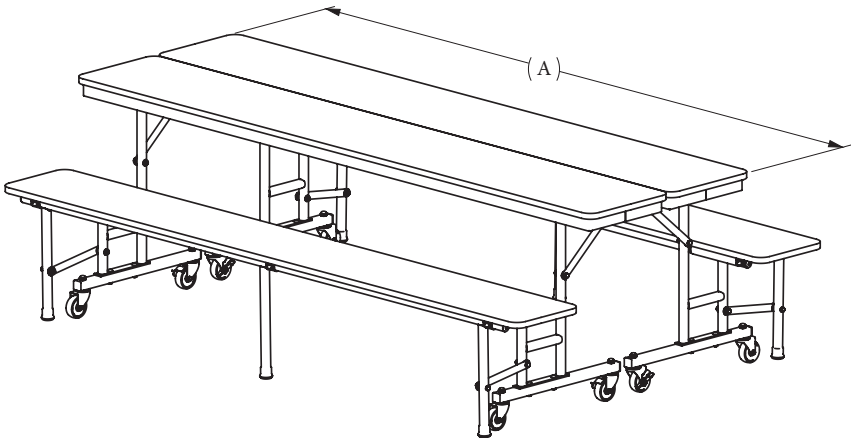

MODEL	OVERALL		
	WIDTH" (A)	DEPTH" (B)	HEIGHT" (C)
ABC89PN	96.0"	57.18"	29.0"

artcobell

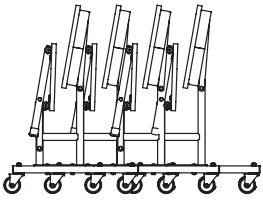

# Convertible Bench Table

## Four Units | Nested Together

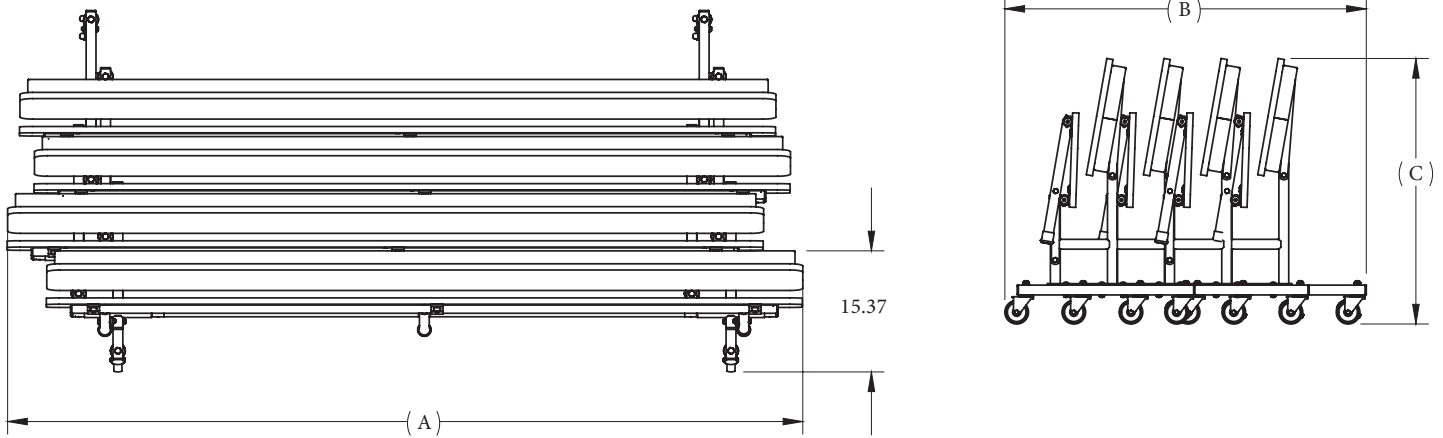

MODEL	OVERALL		
	WIDTH" (A)	DEPTH" (B)	HEIGHT" (C)
ABC89PN	100.96"	45.89"	33.71"

\*The first four (4) units are nested as shown above. The storage pattern then repeats for the next four tables. For every additional convertible bench table the depth increases by 15.37". The width and height remains the same.