

# Linear + Curved Lounge

Configurable upholstered sofas, chairs and ottomans with backs. Cover may be specified in vinyl. Accommodates up to 300 lb. weight capacity.

## Seat frame

Industry leading all steel structure on solid wood base. Back receivers are 1-1/2" 16 gauge steel tube welded to 13 gauge base plate with 13 gauge support gussets, then powder coated and fastened with (9) #10x3/4" wood screws.

## Back frame

Industry leading all steel structure. Inserts are 1-5/16" 16 gauge steel tube welded to a 12 gauge CNC-formed back hoop with 16 gauge cross bar for support. Back frame is then powder coated. Back is secured to couch base by two 3/8" bolts. Couch back is shipped knocked down to reduce shipping cubes. Assembles with two bolts.

## Padding

Foam padding is 1.8/50 ILD foam over 1.8/90 ILD foam on seat and 1.8/34 ILD foam over 1/8/90 ILD foam on the back.

## Cover

Cover may be specified in environmentally friendly wipe clean coated vinyl

## Feet

Adjustable nylon glides.

## Tops

1" thermofused laminate. All four exposed edges of the uprights are banded with 2mm matching PVC. Ottoman top is (dimensions). Wedge top is (dimensions).

## Compliance

- > Certified Indoor Advantage™ Gold. Indoor air quality certified to SCS-EC10.3-2014 V3.0. Registration #SCS-IAQ-03677
- > Indoor Advantage™ Gold. Indoor air quality certified to SCS-EC10.3-2014

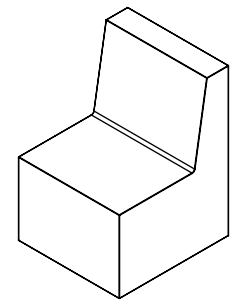
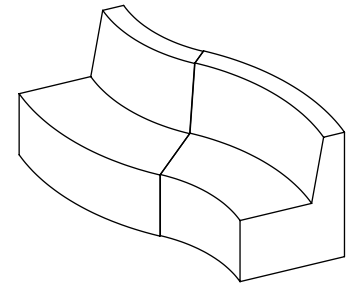

# Linear Lounge Sofa 24"

MODEL	WIDTH"	DEPTH"	HEIGHT"	SEAT DEPTH "
SS-LS24	24.3"	26.3"	36.0"	18.0"
SSD-LS24	24.3"	26.3"	36.0"	18.0"

- 1. GLIDES: QTY 4
- 2. FOAM: 18090 CHARCOAL, 90 IFD/ILD
- 3. FRAME INTERNAL SUPPORT: 12GA ROUND TUBE

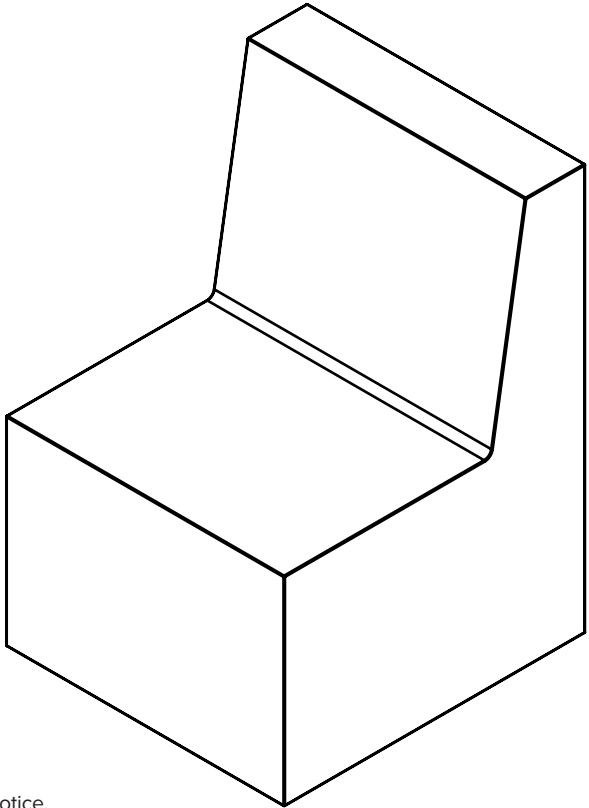

artcobell

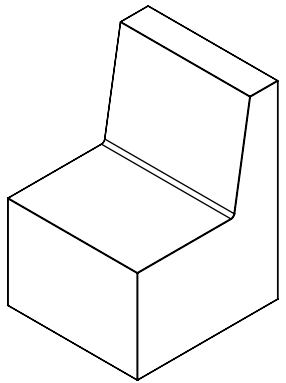

# Linear Lounge Sofa 24"

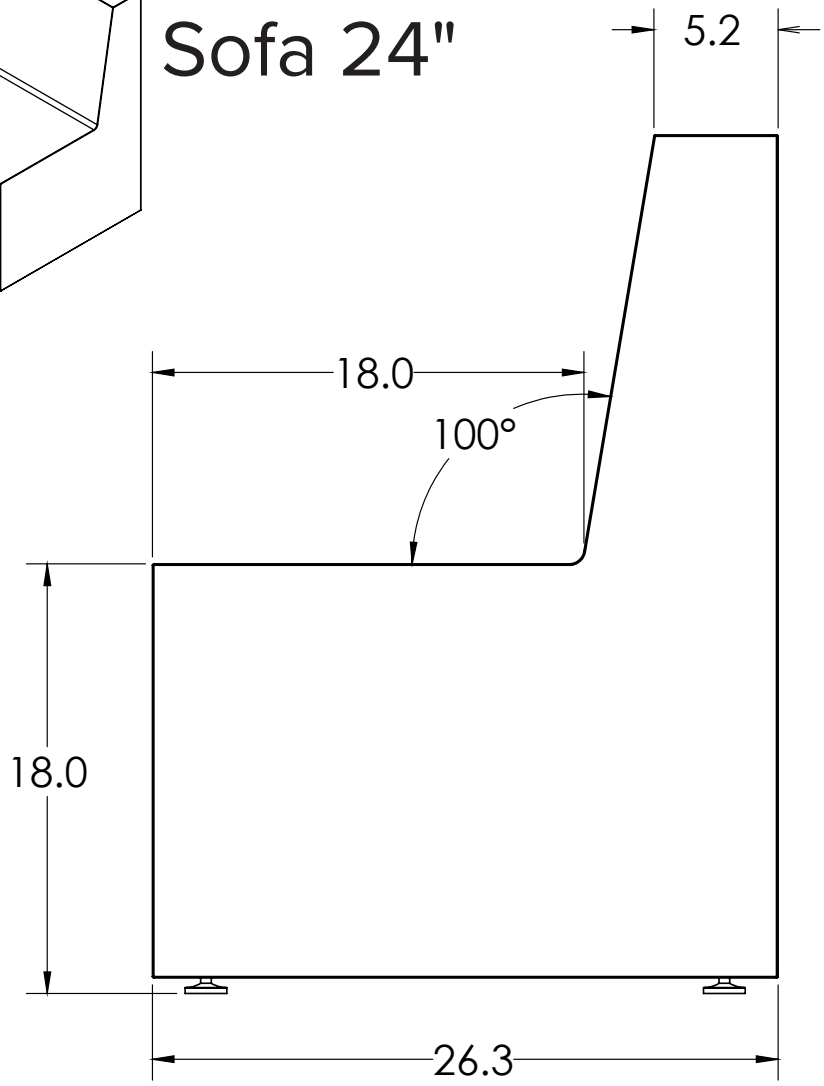

SIDE VIEW

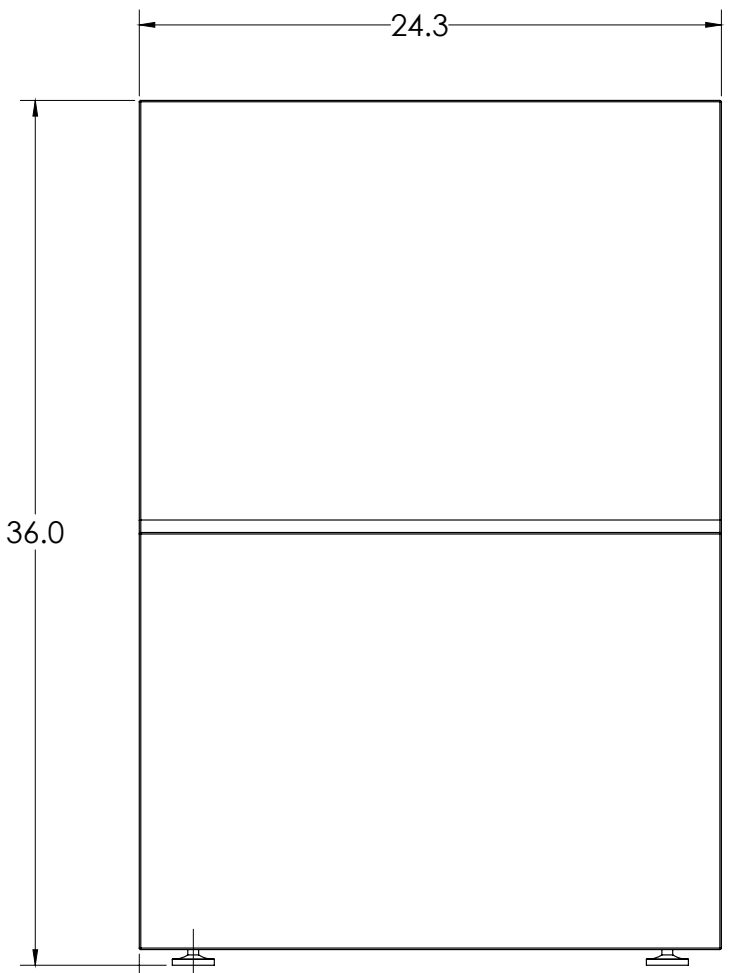

FRONT VIEW

2.0  
GLIDE DISTANCE  
FROM EDGE

artcobell

Artcobell's practice of continuous improvement in design & engineering requires that materials & methods be subject to change without prior notice.

# Linear Lounge Sofa 42"

MODEL	WIDTH"	DEPTH"	HEIGHT"	SEAT DEPTH "
SS-LS42	42.3"	26.3"	36.0"	18.0"
SSD-LS42	42.3"	26.3"	36.0"	18.0"

- 1. GLIDES: QTY 6
- 2. FOAM: 18090 CHARCOAL, 90 IFD/ILD
- 3. FRAME INTERNAL SUPPORT: 12GA ROUND TUBE

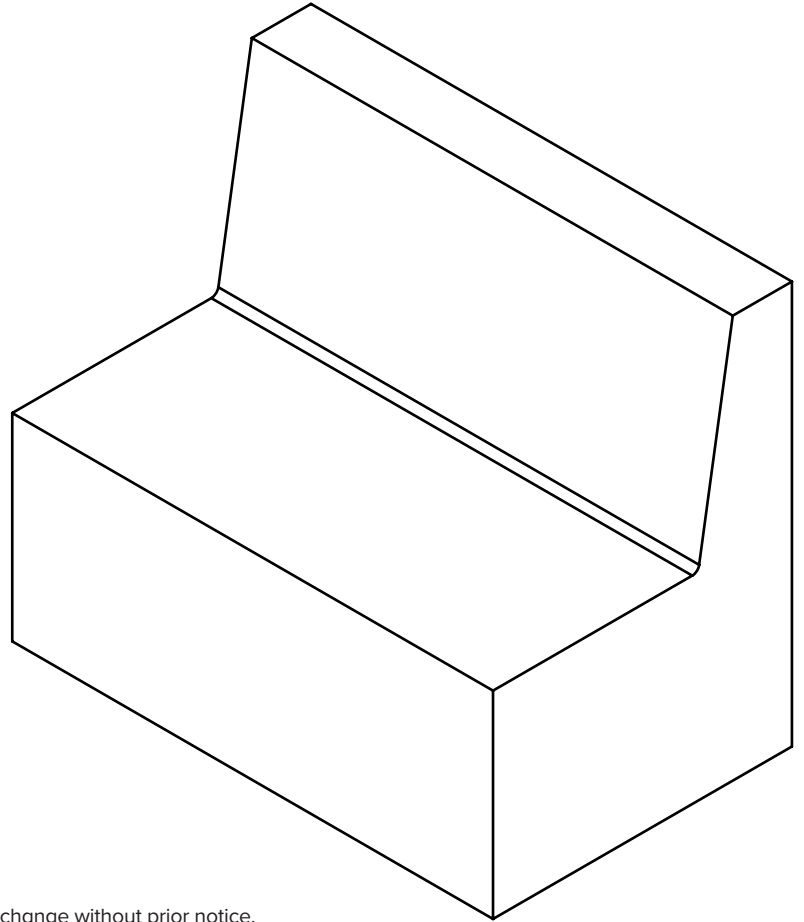

artcobelli

Artcobell's practice of continuous improvement in design & engineering requires that materials & methods be subject to change without prior notice.

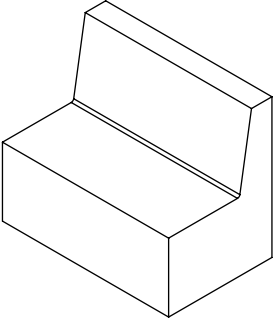

# Linear Lounge Sofa 42"

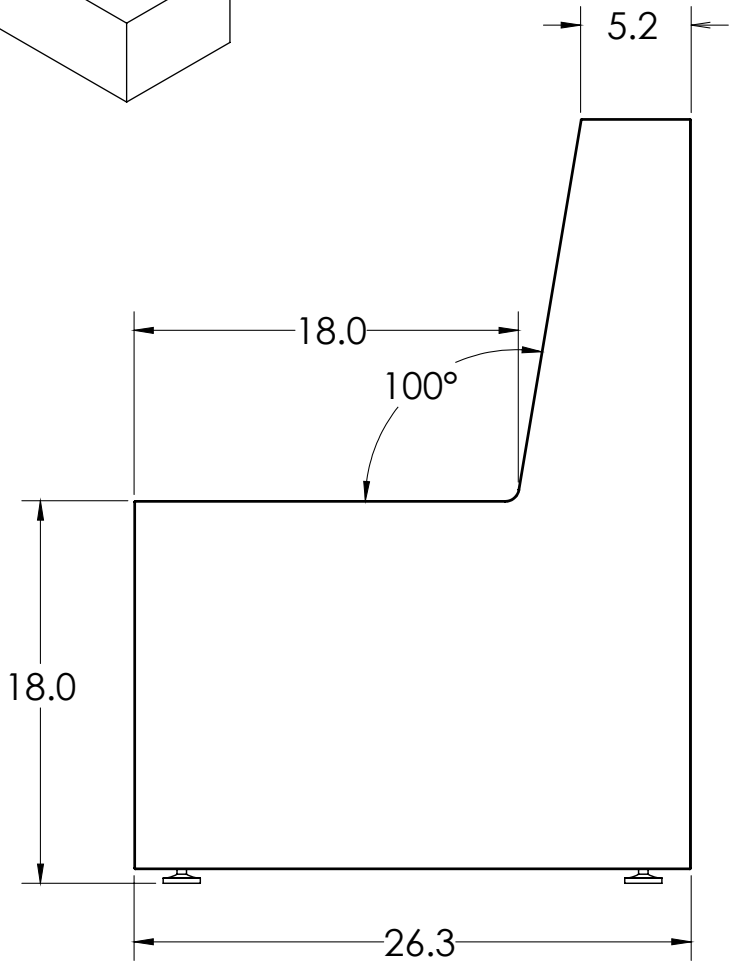

SIDE VIEW

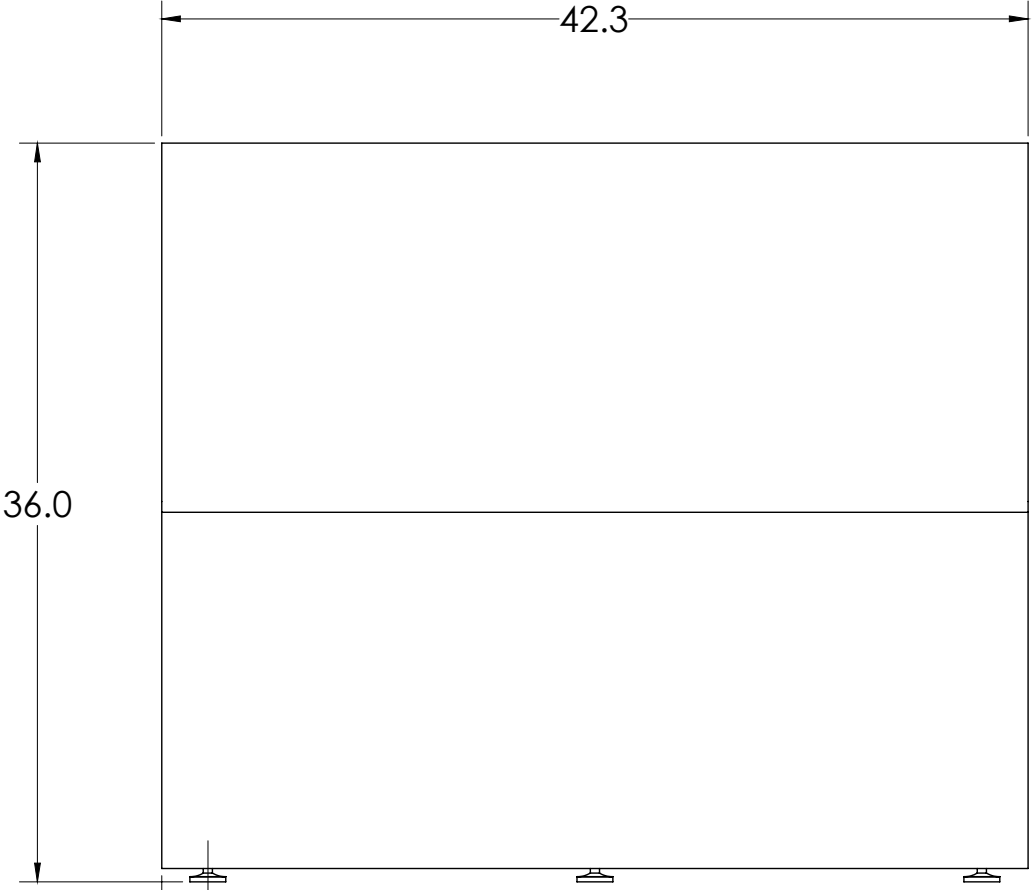

FRONT VIEW

2.0  
GLIDE DISTANCE  
FROM EDGE

artcobelli

Artcobell's practice of continuous improvement in design & engineering requires that materials & methods be subject to change without prior notice.

# Linear Lounge Sofa 48"

MODEL	WIDTH"	DEPTH"	HEIGHT"	SEAT DEPTH "
SS-LS48	48.3"	26.3"	36.0"	18.0"
SSD-LS48	48.3"	26.3"	36.0"	18.0"

1. GLIDES: QTY 6
2. FOAM: 18090 CHARCOAL, 90 IFD/ILD
3. FRAME INTERNAL SUPPORT: 12GA ROUND TUBE

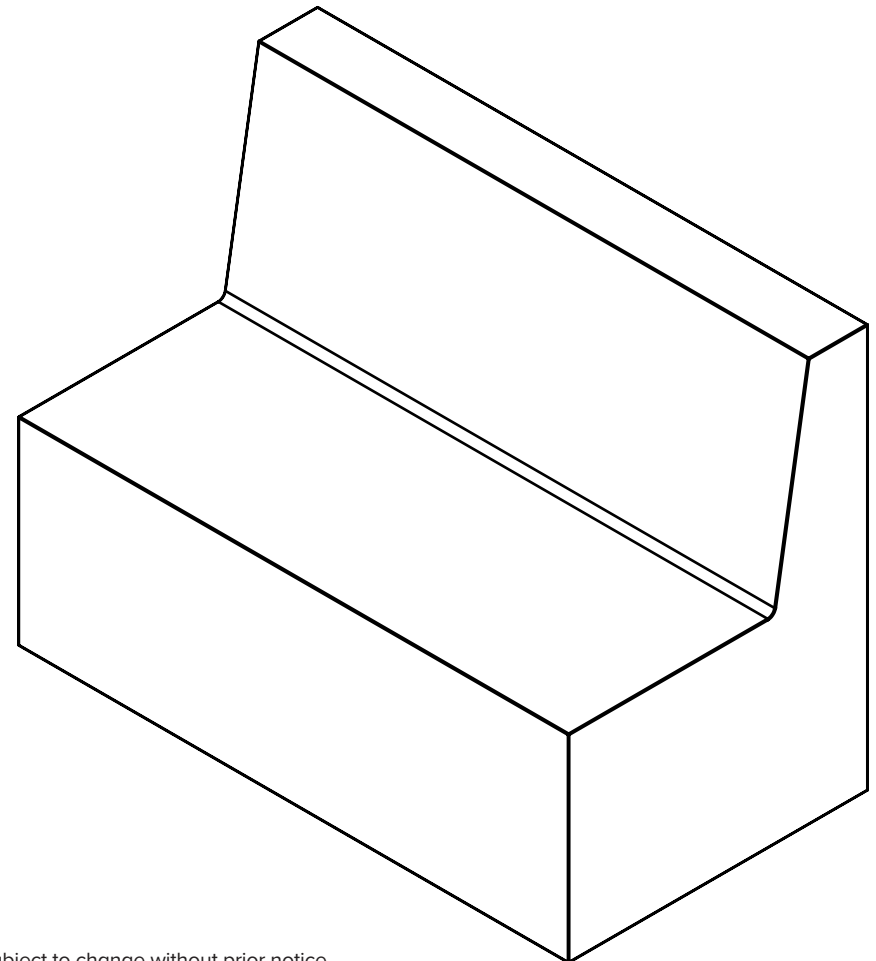

artcobelli

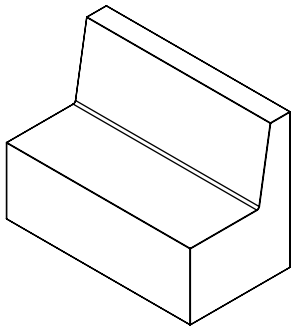

# Linear Lounge Sofa 48"

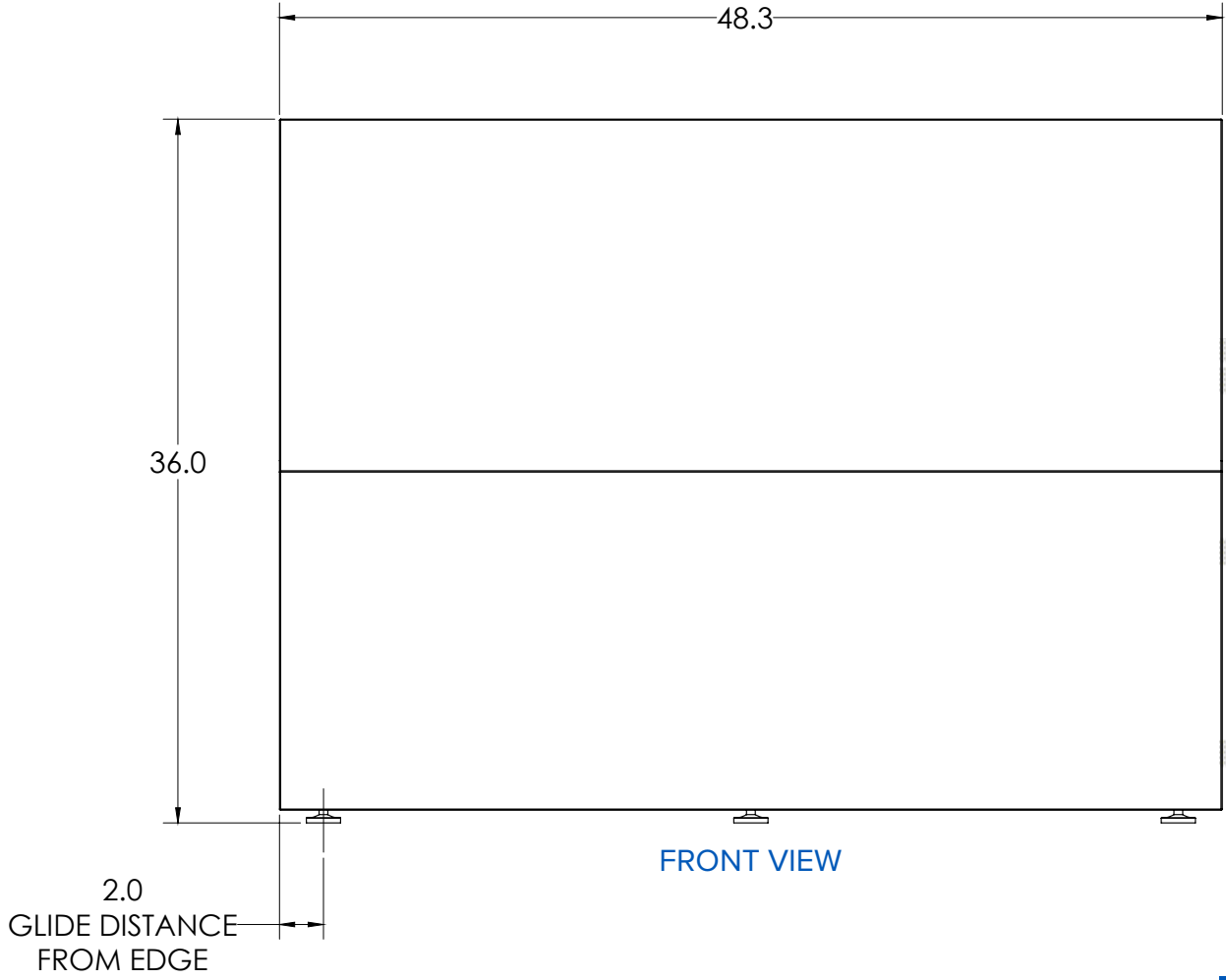
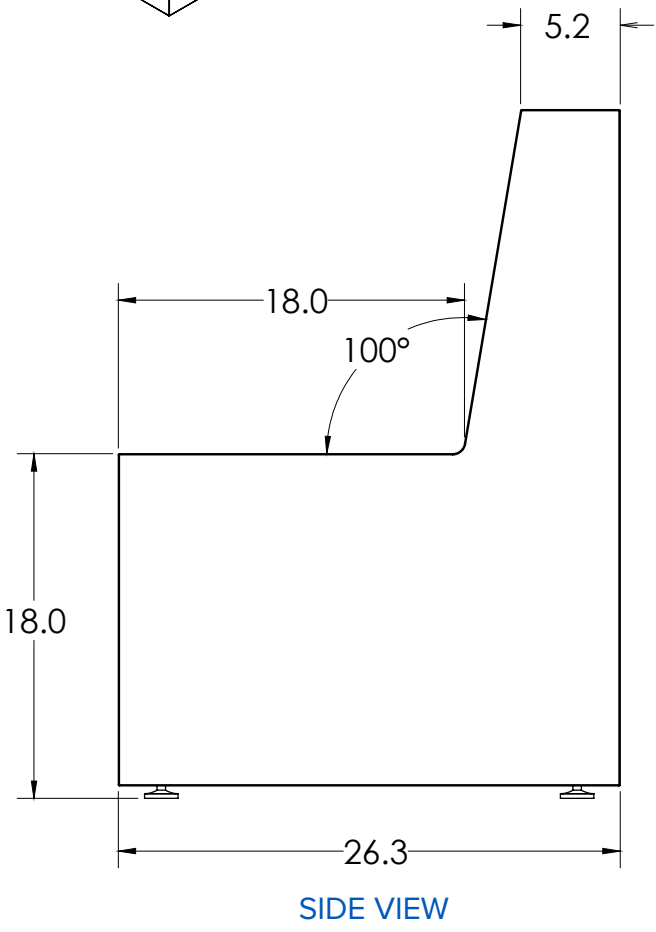

artcobell

# Linear Lounge Sofa 60"

MODEL	WIDTH"	DEPTH"	HEIGHT"	SEAT DEPTH "
SS-LS60	60.3"	26.3"	36.0"	18.0"
SSD-LS60	60.3"	26.3"	36.0"	18.0"

1. GLIDES: QTY 6
2. FOAM: 18090 CHARCOAL, 90 IFD/ILD
3. FRAME INTERNAL SUPPORT: 12GA ROUND TUBE

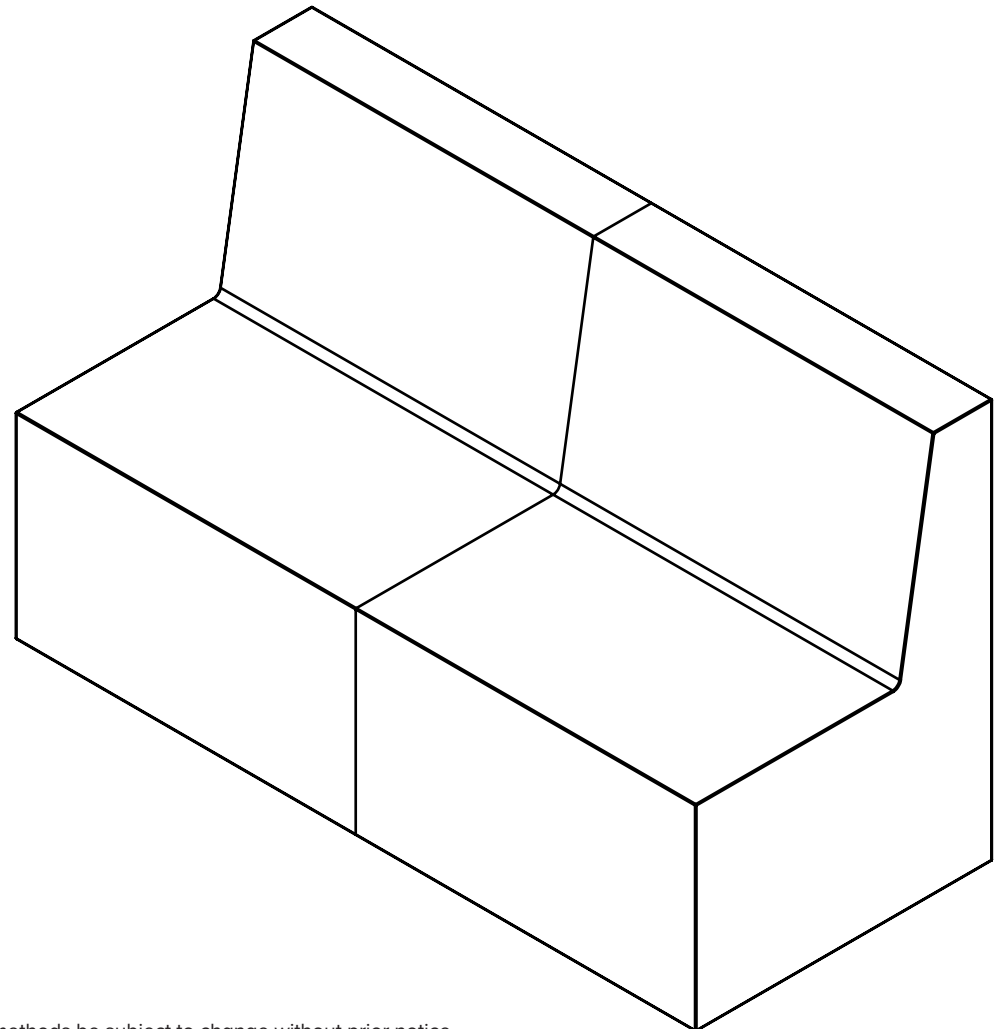

artcobelli



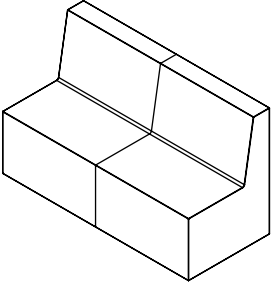

# Linear Lounge Sofa 60"

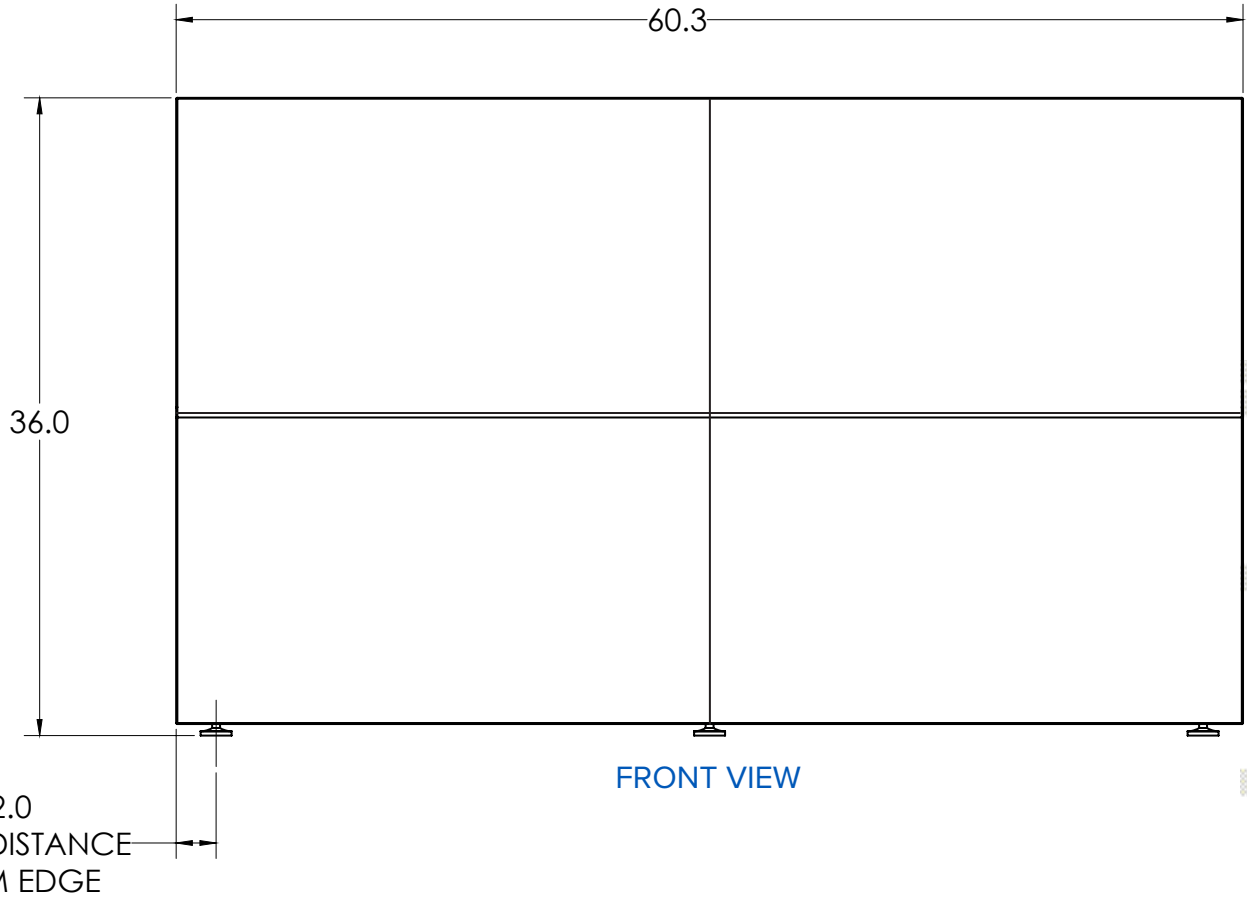
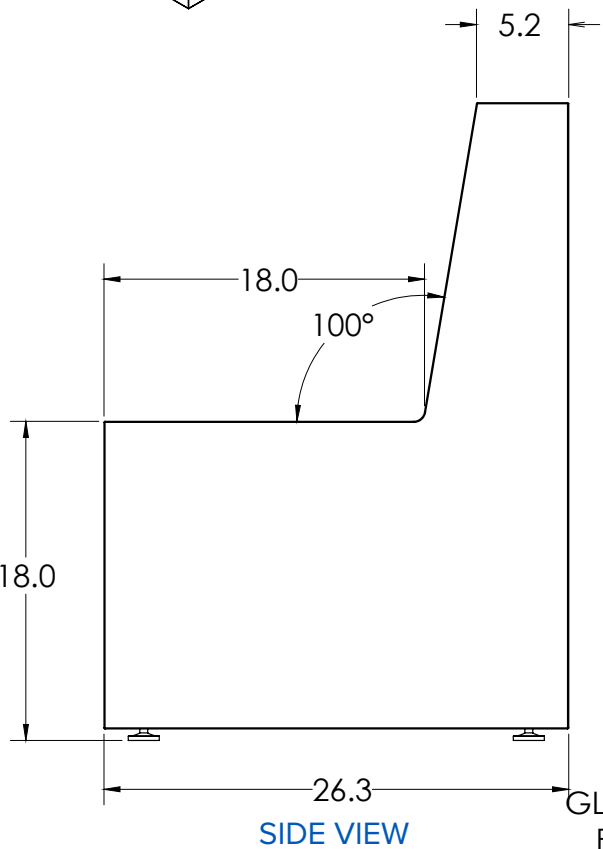

artcobell

# Linear Lounge

## Corner

MODEL	WIDTH"	DEPTH"	HEIGHT"	SEAT DEPTH "
SS-LC26	26.3"	26.3"	36"	18"
SSD-LC26	26.3"	26.3"	36"	18"

1. GLIDES: QTY 4
2. FOAM: 18090 CHARCOAL, 90 IFD/ILD
3. FRAME INTERNAL SUPPORT: 12GA ROUND TUBE

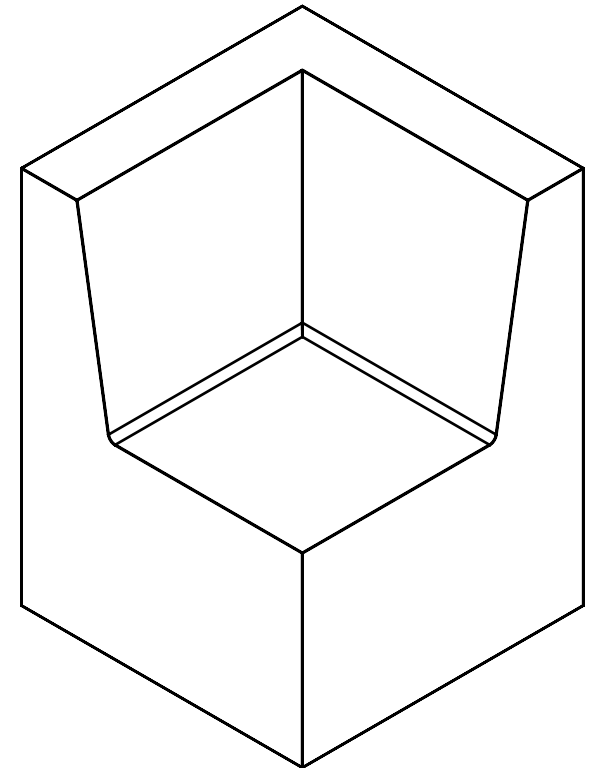

artcobell

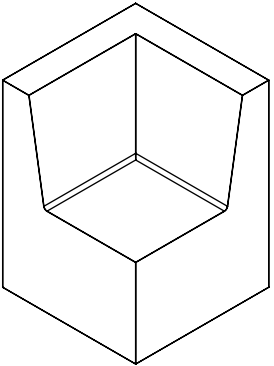

# Linear Lounge Corner

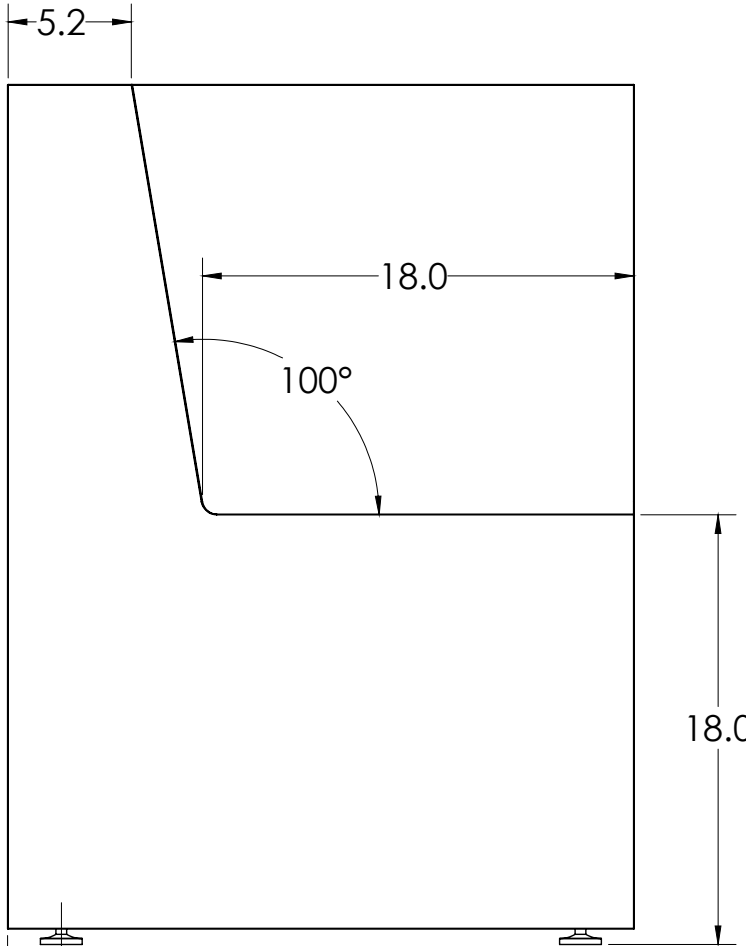

SIDE VIEW

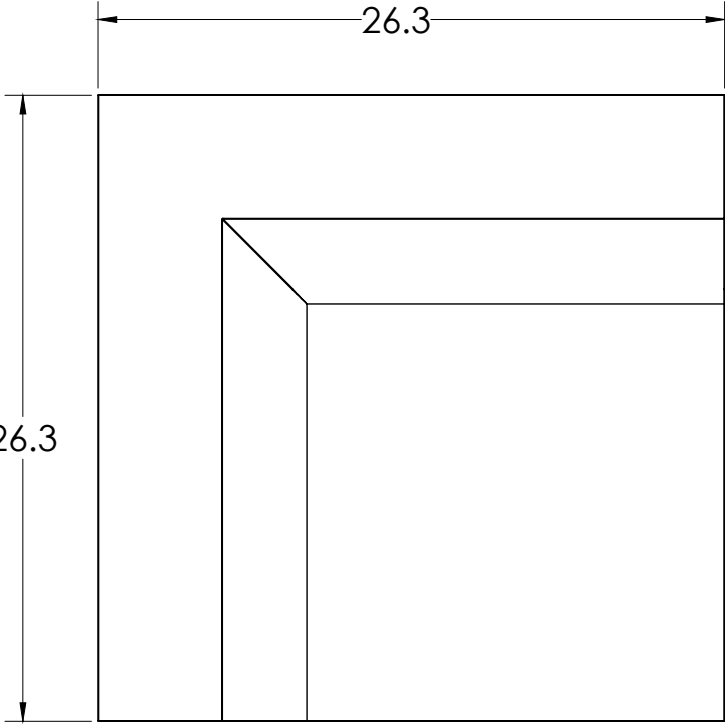

TOP VIEW

2.0  
GLIDE DISTANCE  
FROM EDGE

artcobelli

Artcobell's practice of continuous improvement in design & engineering requires that materials & methods be subject to change without prior notice.

# Linear Lounge | Ottoman Square

MODEL	WIDTH"	DEPTH"	HEIGHT"
SS-SQ2618	26.3"	26.3"	18"
SS-SQ2618T	26.3"	26.3"	19.3"
SSD-SQ2618	26.3"	26.3"	18"

1. GLIDES: QTY 4. ALL GLIDES INSET FROM OUTER EDGE 2"
2. LAMINATE TOP WITH EDGEBAND: 1 in THICK
  - TOP INSET TO UNIT BODY BY .5in
  - TOP SECURED TO UNITS WITH HIDDEN HEAVY DUTY CLIP FASTENER SEWN ONTO FABRIC OF UNIT.
3. FOAM: 18090 CHARCOAL, 90 IFD/ILD

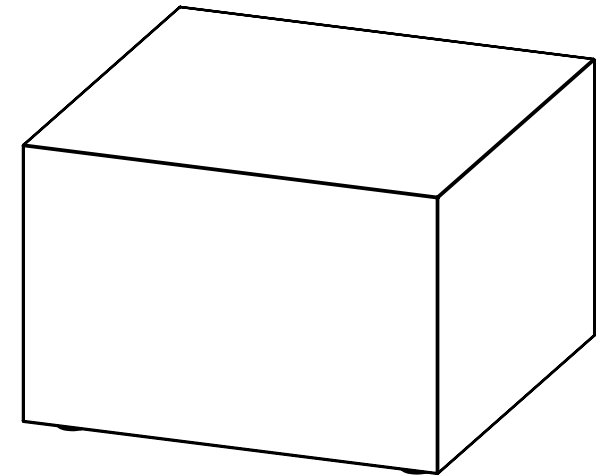
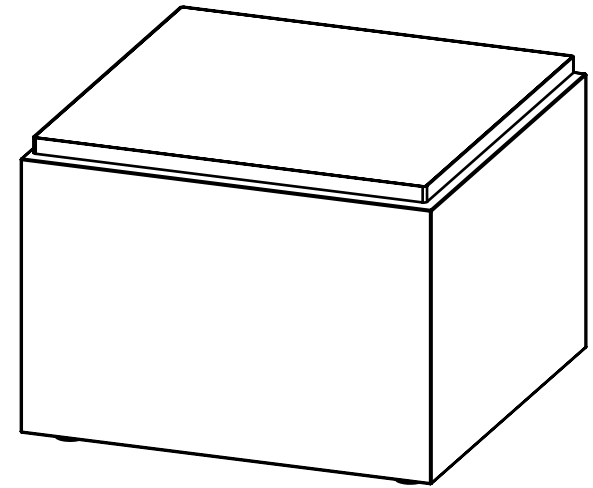

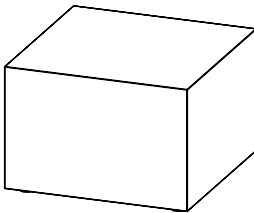

# Linear Lounge | Ottoman Square

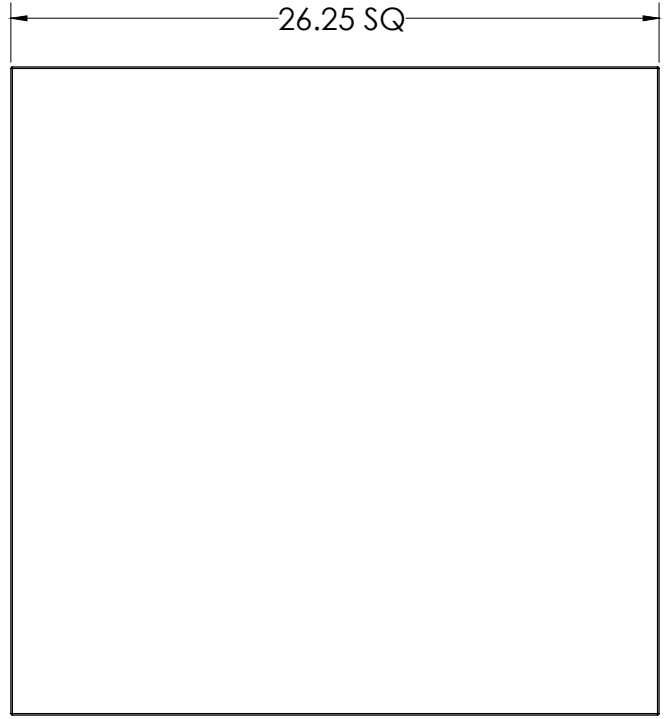

TOP VIEW

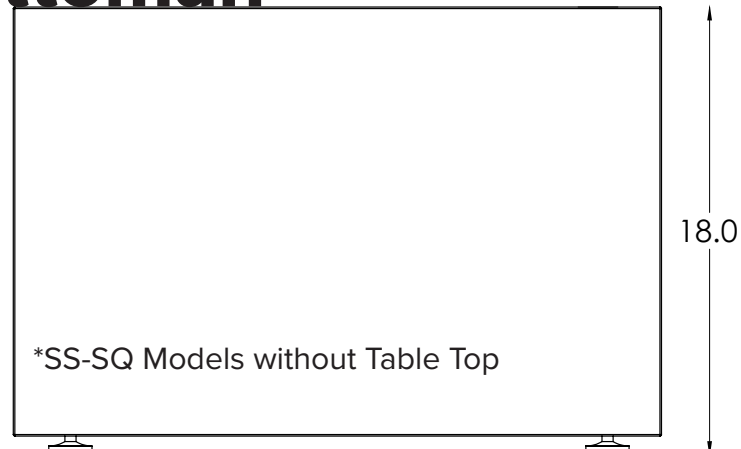

\*SS-SQ Models without Table Top

SIDE VIEW

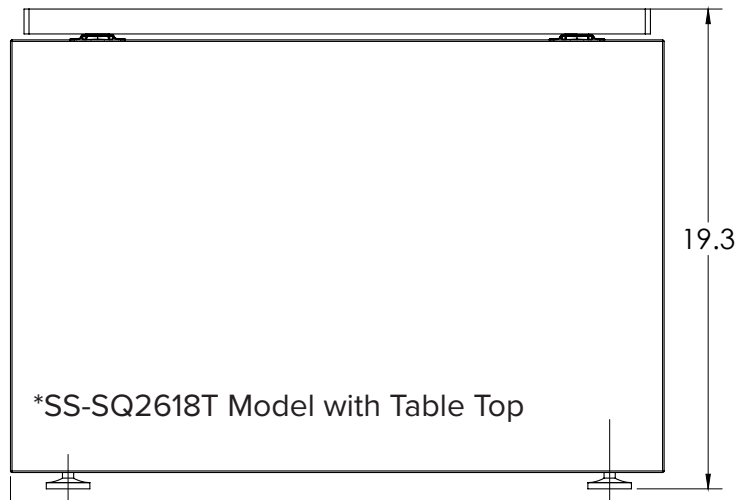

\*SS-SQ2618T Model with Table Top

SIDE VIEW

2.0  
GLIDE DISTANCE  
FROM EDGE

artcobelli

# Linear Lounge | Ottoman Wedge

MODEL	WIDTH"	DEPTH"	HEIGHT"
SS-WD2618	26.2"	26.2"	18"
SS-WD2618T	26.2"	26.2"	19.3"
SSD-WD2618	26.2"	26.2"	18"

1. GLIDES: QTY 4. ALL GLIDES INSET FROM OUTER EDGE 2"
2. LAMINATE TOP WITH EDGE BAND: 1 in THICK
  - TOP INSET TO UNIT BODY BY .5in
  - TOP SECURED TO UNITS WITH HIDDEN HEAVY DUTY CLIP FASTENER SEWN ONTO FABRIC OF UNIT.
3. FOAM: 18090 CHARCOAL, 90 IFD/ILD

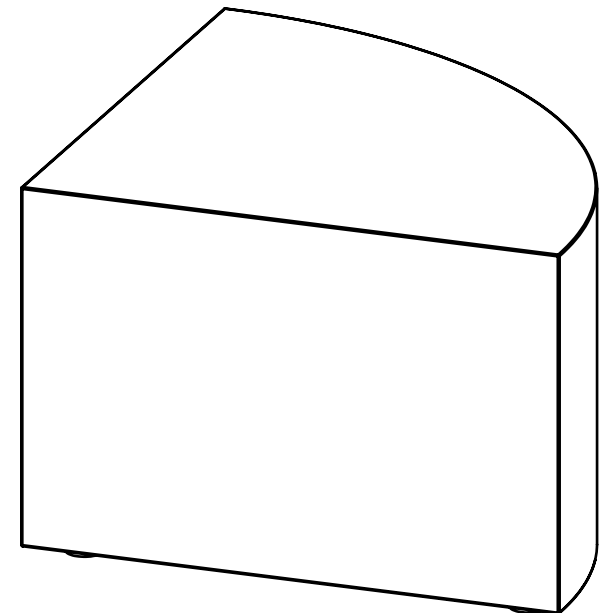
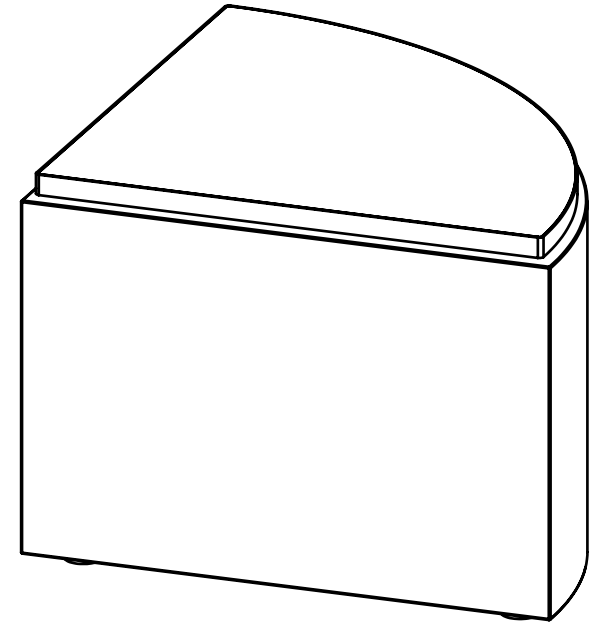

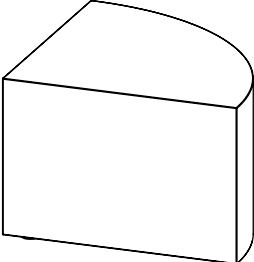

# Linear Lounge | Ottoman Wedge

\*SS-WD Models without Table Top

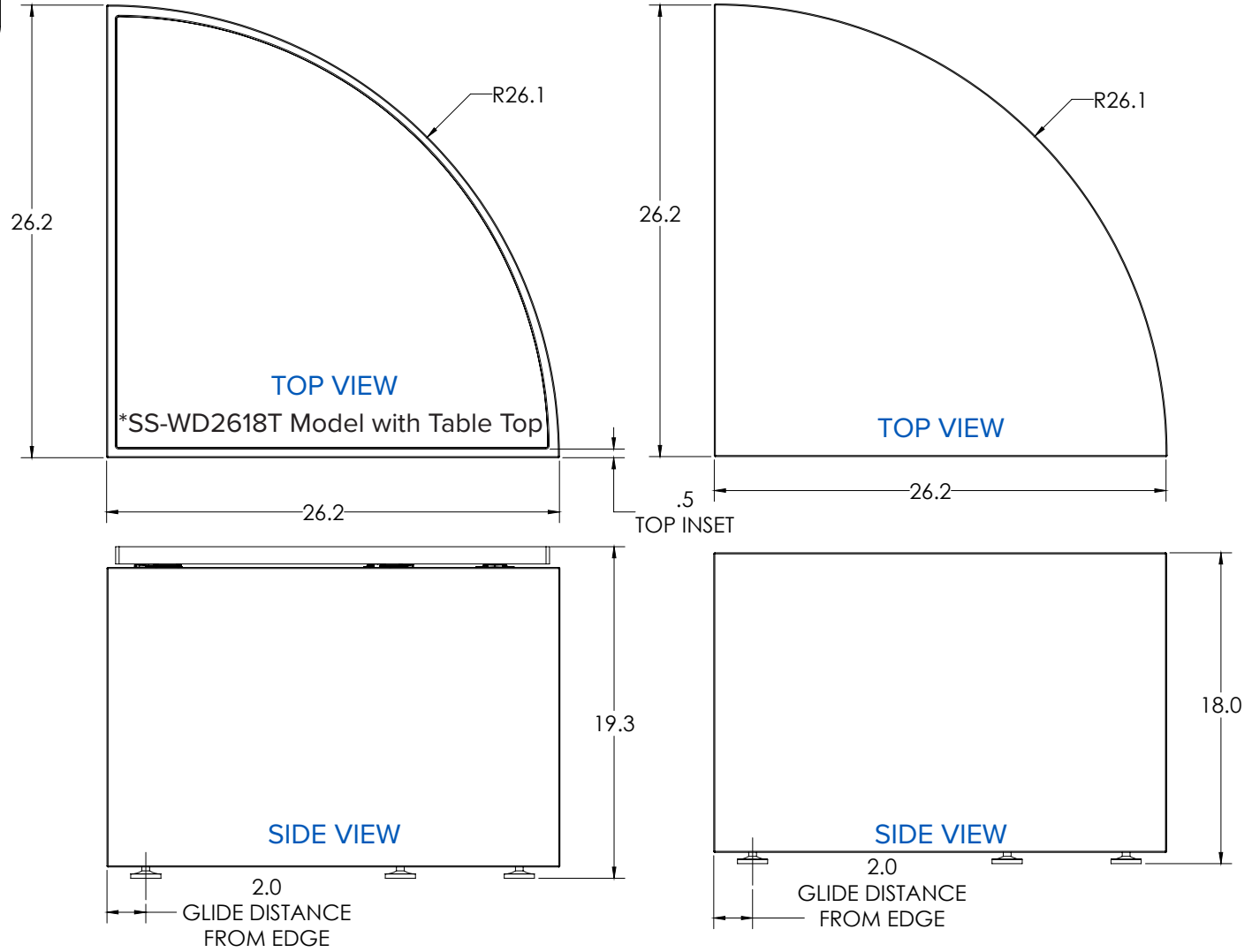

artcobell

Artcobell's practice of continuous improvement in design & engineering requires that materials & methods be subject to change without prior notice.

# Curved Lounge | Sofa

## Inside Curve | 45° Radius

MODEL	WIDTH"	DEPTH"	HEIGHT"	SEAT DEPTH "
SS-CSI45	46.2"	28.9"	36"	18"
SSD-CSI45	46.2"	28.9"	36"	18"

- CURVED SOFA IN AT 45 DEGREE TOP VIEW.
- MAIN COMPONENTS OF FINAL ASSEMBLY [FULLY ASSEMBLED]:
  - FOAM: 18090 STANDARD INDUSTRY GRADE.
  - FABRIC: DESIGN CHOICE SPECIFIC TO CUSTOMER, SECURED TO UNIT WITH STAPLES ONTO WOOD BASE.
  - WOODBASE: 0.75" THICK MDF WITH BACKER BROWN, GLUED TO FOAM UNIT.
  - FRAME: 12GA, 1-1/8in METAL TUBE SUPPORT [SITS INSIDE FOAM, UNDETECTED BY USER].
- ADJUSTABLE THREADED GLIDES: 5 QTY.
- CASTER AND SOFA BENCH LEGS NOT RECOMMENDED.
- STORAGE MODEL UNIT MATCH:
  - ASFVSC-1742
  - ASFVSC-1748

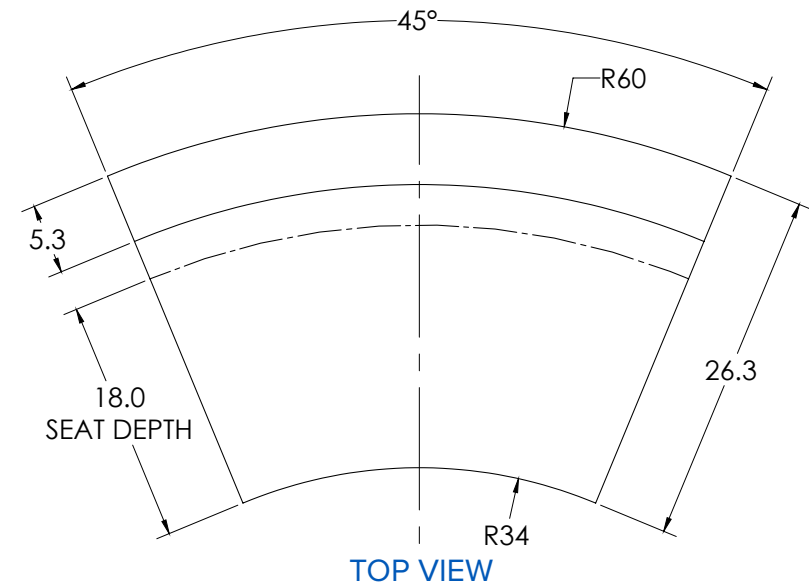
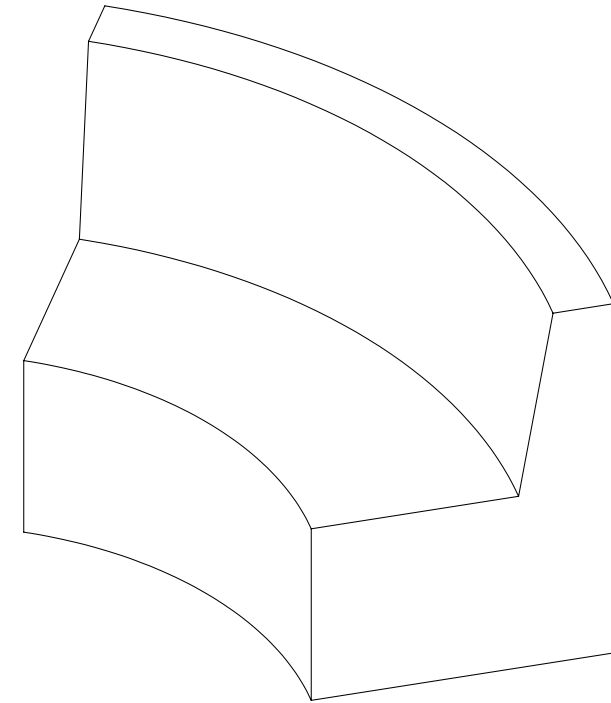



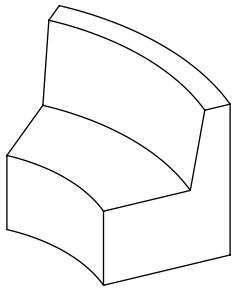

# Curved Lounge | Sofa

## Inside Curve | 45° Radius

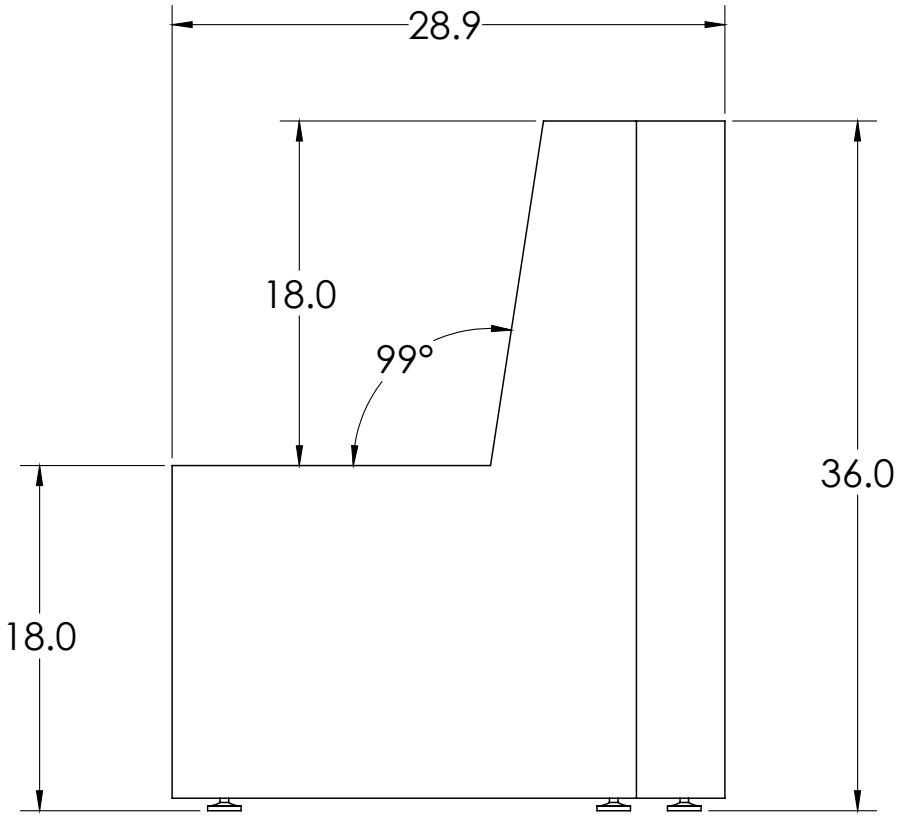

SIDE VIEW

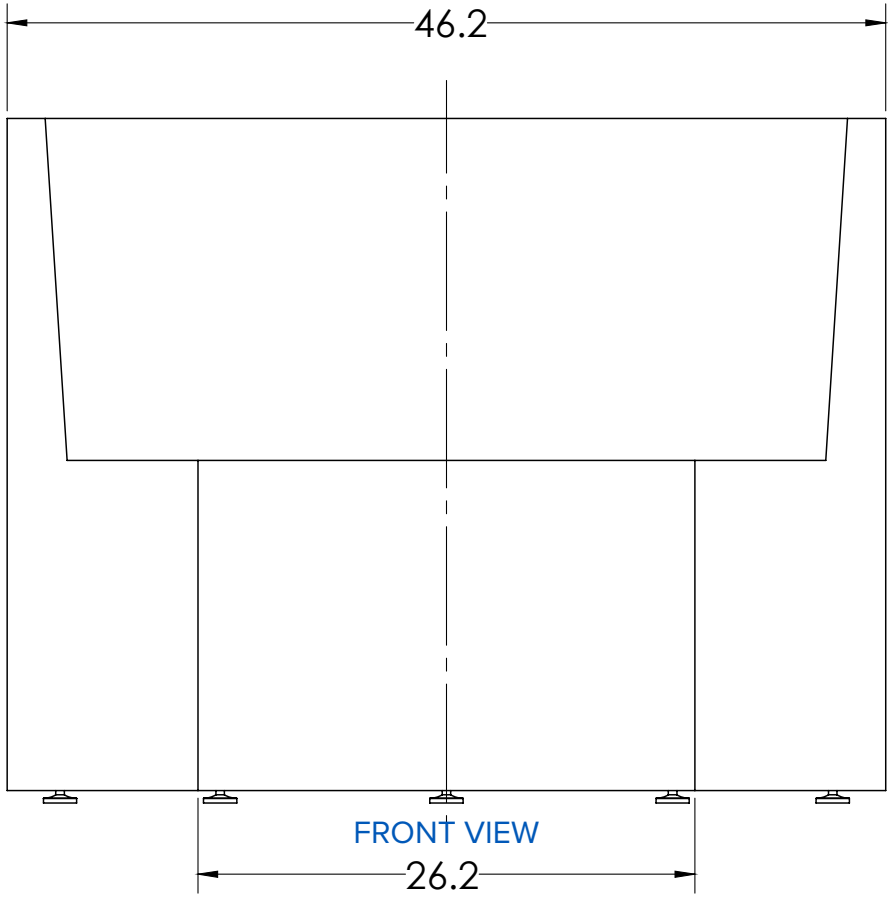

FRONT VIEW

artcobelli

Artcobelli's practice of continuous improvement in design & engineering requires that materials & methods be subject to change without prior notice.

# Curved Lounge | Sofa

## Inside Curve | 60° Radius

MODEL	WIDTH"	DEPTH"	HEIGHT"	SEAT DEPTH "
SS-CSI60	60.3"	30.9"	36"	18"
SSD-CSI60	60.3"	30.9"	36"	18"

- CURVED SOFA IN AT 60 DEGREE TOP VIEW.
- MAIN COMPONENTS OF FINAL ASSEMBLY [FULLY ASSEMBLED]:
  - FOAM: 18090 STANDARD INDUSTRY GRADE.
  - FABRIC: DESIGN CHOICE SPECIFIC TO CUSTOMER, SECURED TO UNIT WITH STAPLES ONTO WOOD BASE.
  - WOODBASE: 0.75" THICK MDF WITH BACKER BROWN, GLUED TO FOAM UNIT.
  - FRAME: 12GA, 1-1/8in METAL TUBE SUPPORT [SITS INSIDE FOAM, UNDETECTED BY USER].
- ADJUSTABLE THREADED GLIDES: 6 QTY.
- CASTER AND SOFA BENCH LEGS NOT RECOMMENDED.
- STORAGE MODEL UNIT MATCH:
  - ASFVSC-1742
  - ASFVSC-1748

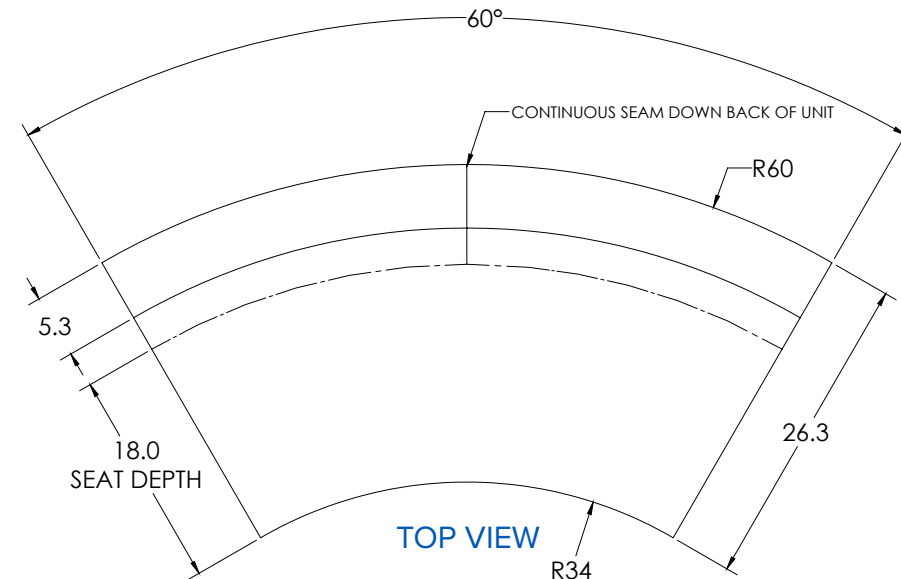
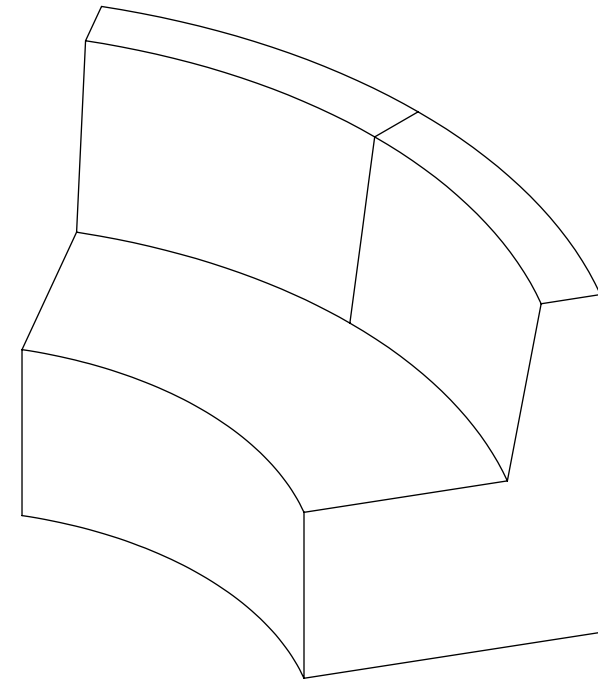

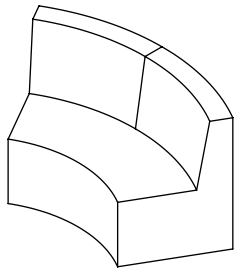

# Curved Lounge | Sofa

## Inside Curve | 60° Radius

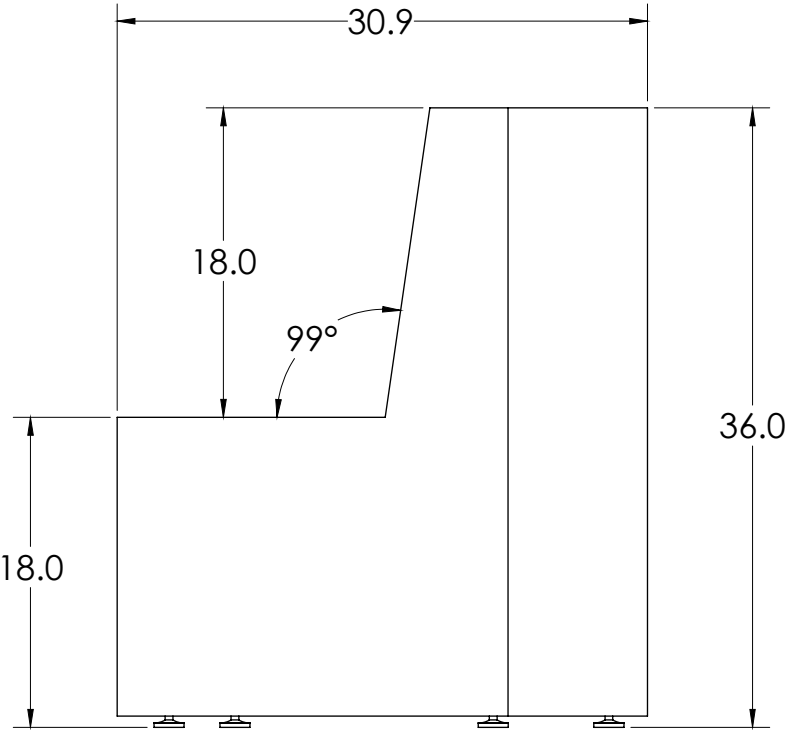

SIDE VIEW

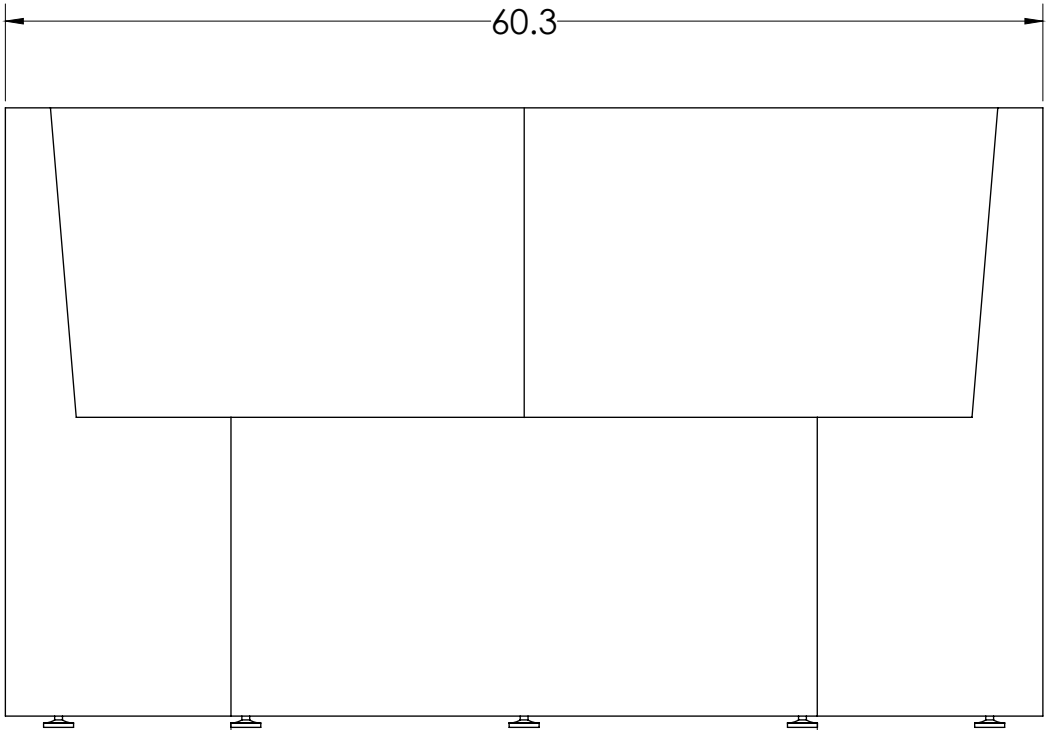

FRONT VIEW

artcobelli

# Curved Lounge | Sofa

## Outside Curve | 45° Radius

MODEL	WIDTH"	DEPTH"	HEIGHT"	SEAT DEPTH "
SS-CSO45	46.2"	28.9"	36"	18"
SSD-CSO45	46.2"	28.9"	36"	18"

- CURVED SOFA OUT AT 45 DEGREE TOP VIEW.
- MAIN COMPONENTS OF FINAL ASSEMBLY [FULLY ASSEMBLED]:
  - FOAM: 18090 STANDARD INDUSTRY GRADE.
  - FABRIC: DESIGN CHOICE SPECIFIC TO CUSTOMER, SECURED TO UNIT WITH STAPLES ONTO WOOD BASE.
  - WOODBASE: 0.75" THICK MDF WITH BACKER BROWN, GLUED TO FOAM UNIT.
  - FRAME: 12GA, 1-1/8in METAL TUBE SUPPORT [SITS INSIDE FOAM, UNDETECTED BY USER].
- ADJUSTABLE THREADED GLIDES: 5 QTY.
- CASTER AND SOFA BENCH LEGS NOT RECOMMENDED.
- STORAGE MODEL UNIT MATCH: NA

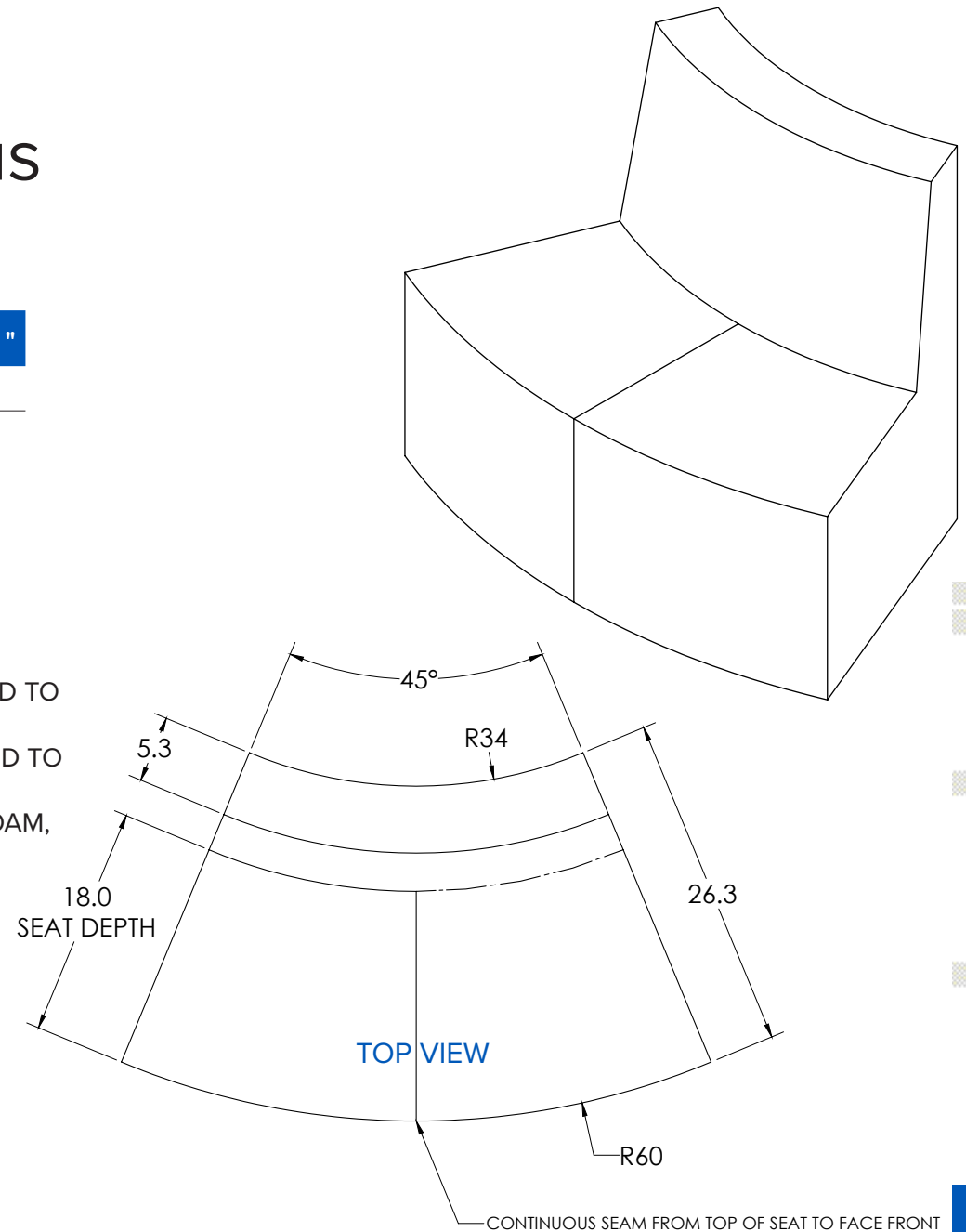

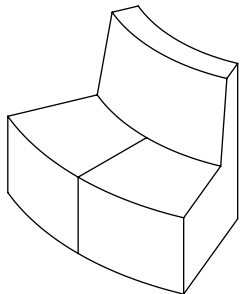

# Curved Lounge | Sofa

## Outside Curve | 45° Radius

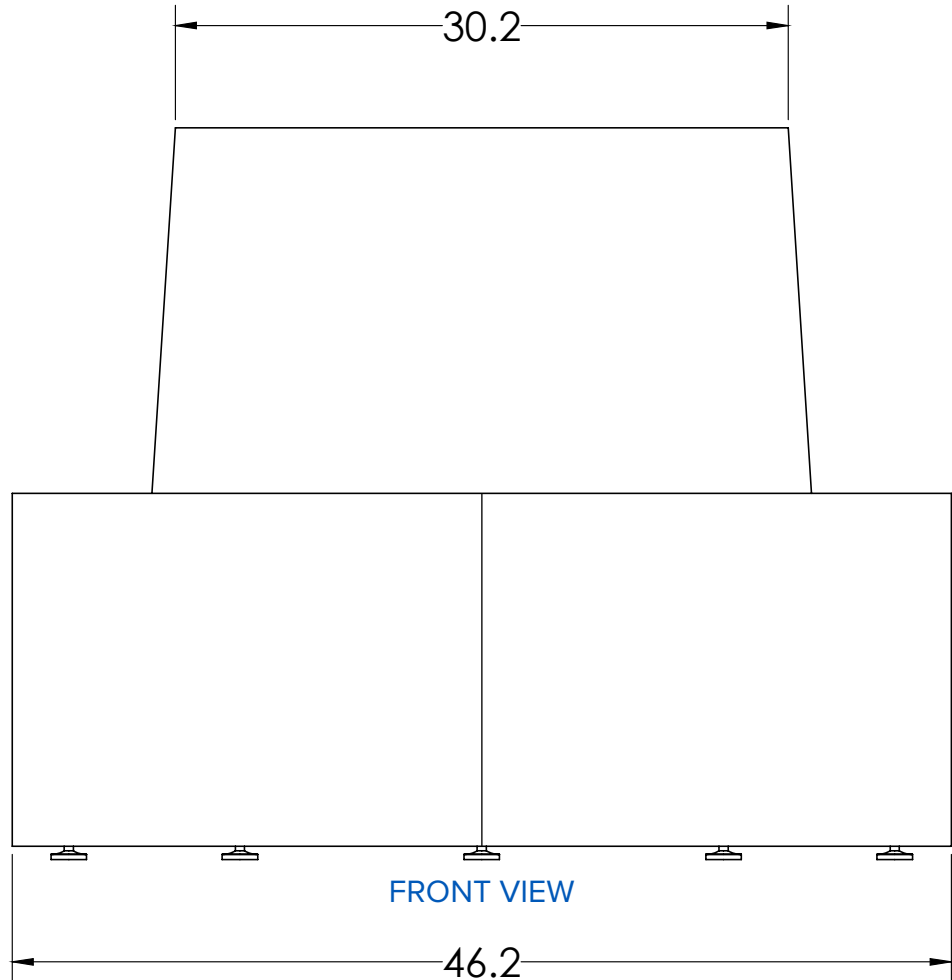
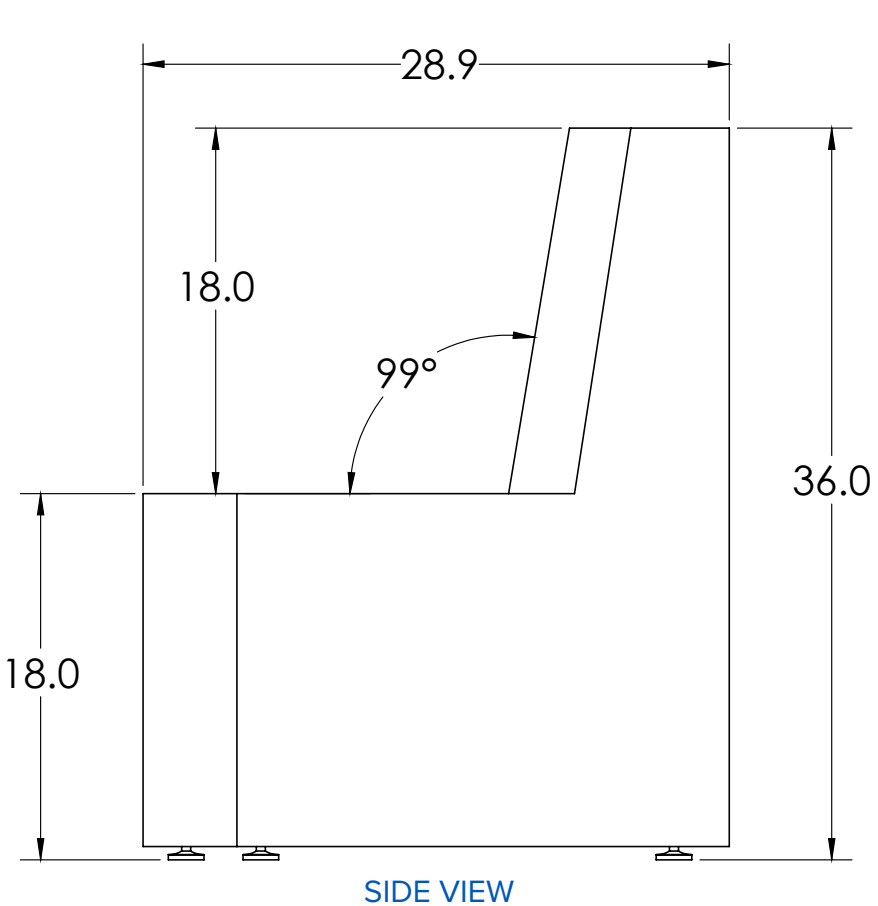

artcobelli

# Curved Lounge | Sofa

## Outside Curve | 60° Radius

MODEL	WIDTH"	DEPTH"	HEIGHT"	SEAT DEPTH "
SS-CSO60	60.3"	30.9"	36"	18"
SSD-CSO60	60.3"	30.9"	36"	18"

- CURVED SOFA OUT AT 60 DEGREE TOP VIEW.
- MAIN COMPONENTS OF FINAL ASSEMBLY [FULLY ASSEMBLED]:
  - FOAM: 18090 STANDARD INDUSTRY GRADE.
  - FABRIC: DESIGN CHOICE SPECIFIC TO CUSTOMER, SECURED TO UNIT WITH STAPLES ONTO WOOD BASE.
  - WOODBASE: 0.75" THICK MDF WITH BACKER BROWN, GLUED TO FOAM UNIT.
  - FRAME: 12GA, 1-1/8in METAL TUBE SUPPORT [SITS INSIDE FOAM, UNDETECTED BY USER].
- ADJUSTABLE THREADED GLIDES: 6 QTY.
- CASTER AND SOFA BENCH LEGS NOT RECOMMENDED.
- STORAGE MODEL UNIT MATCH: NA

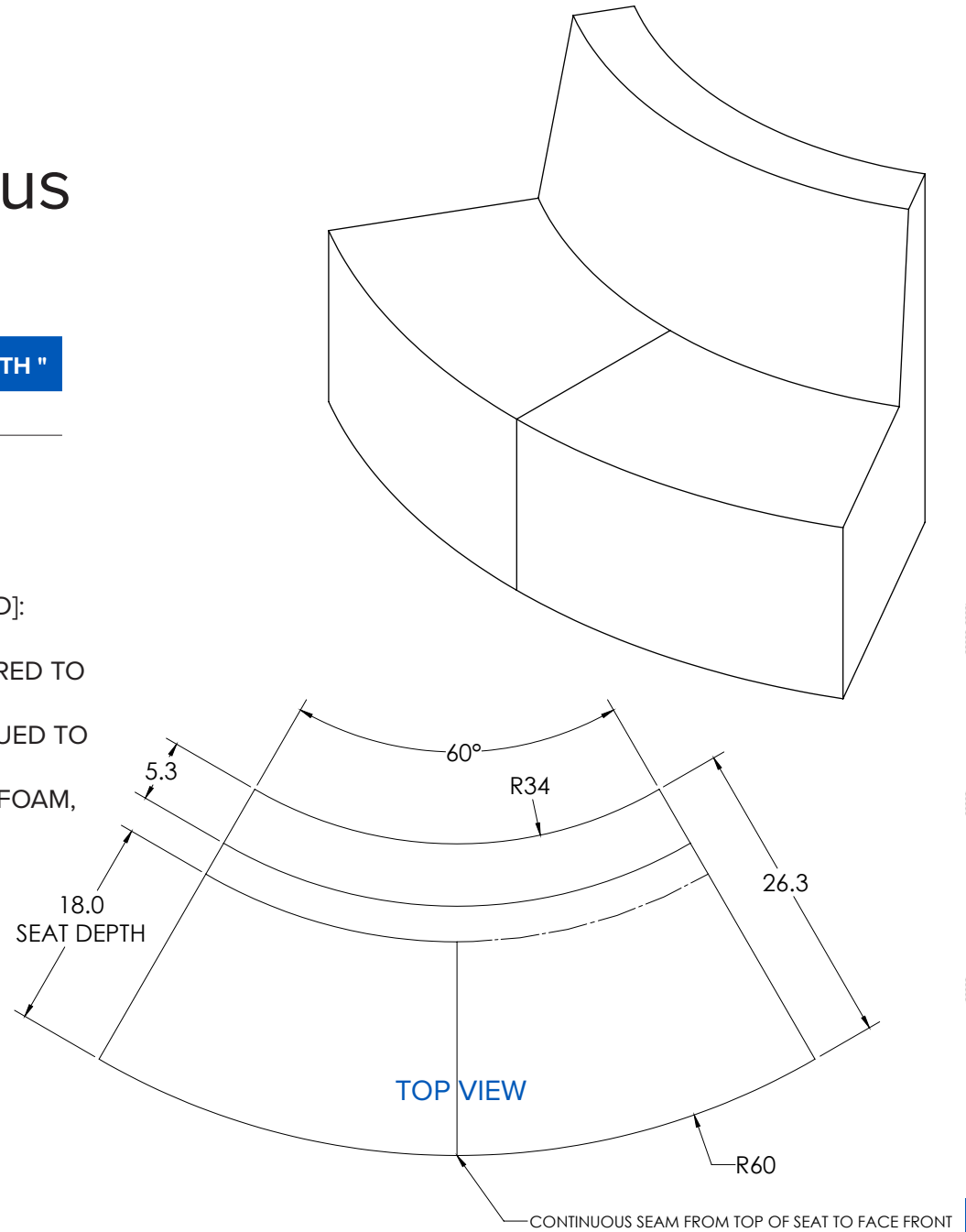

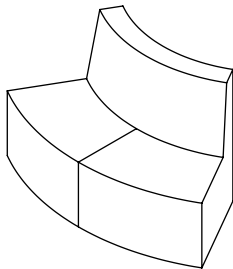

# Curved Lounge | Sofa

## Outside Curve | 60° Radius

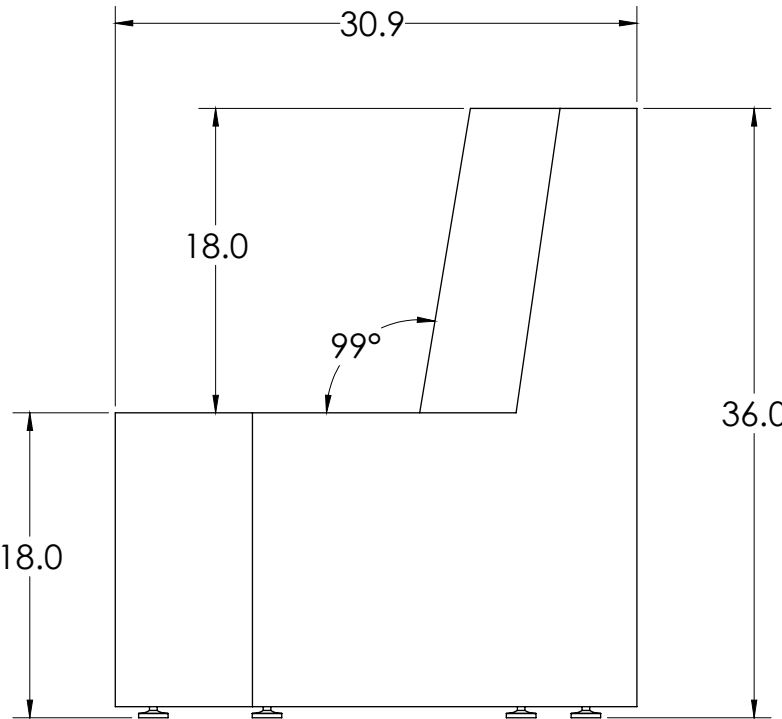

SIDE VIEW

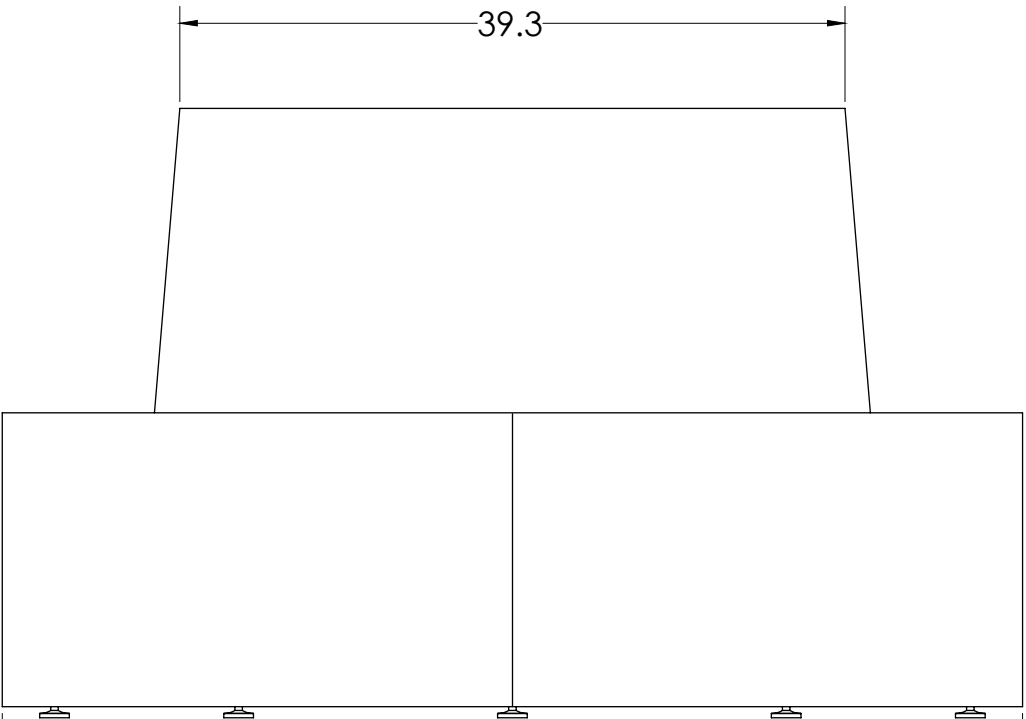

FRONT VIEW

artcobelli