

Coat Locker

18" deep and 60" wide cabinet is single-sided, open-faced with thermofused-melamine cladding. All interior shelves fixed.

Ends, Partitions and Shelves

1" thermofused laminate. All exposed edges of the uprights are banded with 2mm matching PVC. Each section is 10.8". The front fascia board is 1" thick, 3.7" x 58" thermofused laminate, tops and uprights are cam locked in place. Backs are 1" thick matching thermofused laminate on particleboard. There are a total of 10 hooks (2 in each cubbie). Hooks are placed at 20.8" above lower shelf, 36.9" from ground. Parts are milled for continual assembly in long runs of shelving. All base parts are a minimum 1"-thick thermofused laminate.

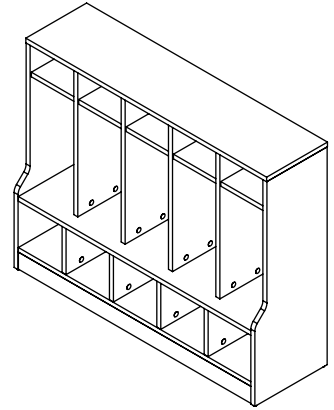

Compliance

- > Tested to applicable ANSI/BIFMA Furniture Standards
- > MAS Certified Green, certificate #MAS1800444

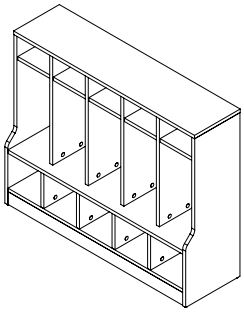

Storage Coat Locker

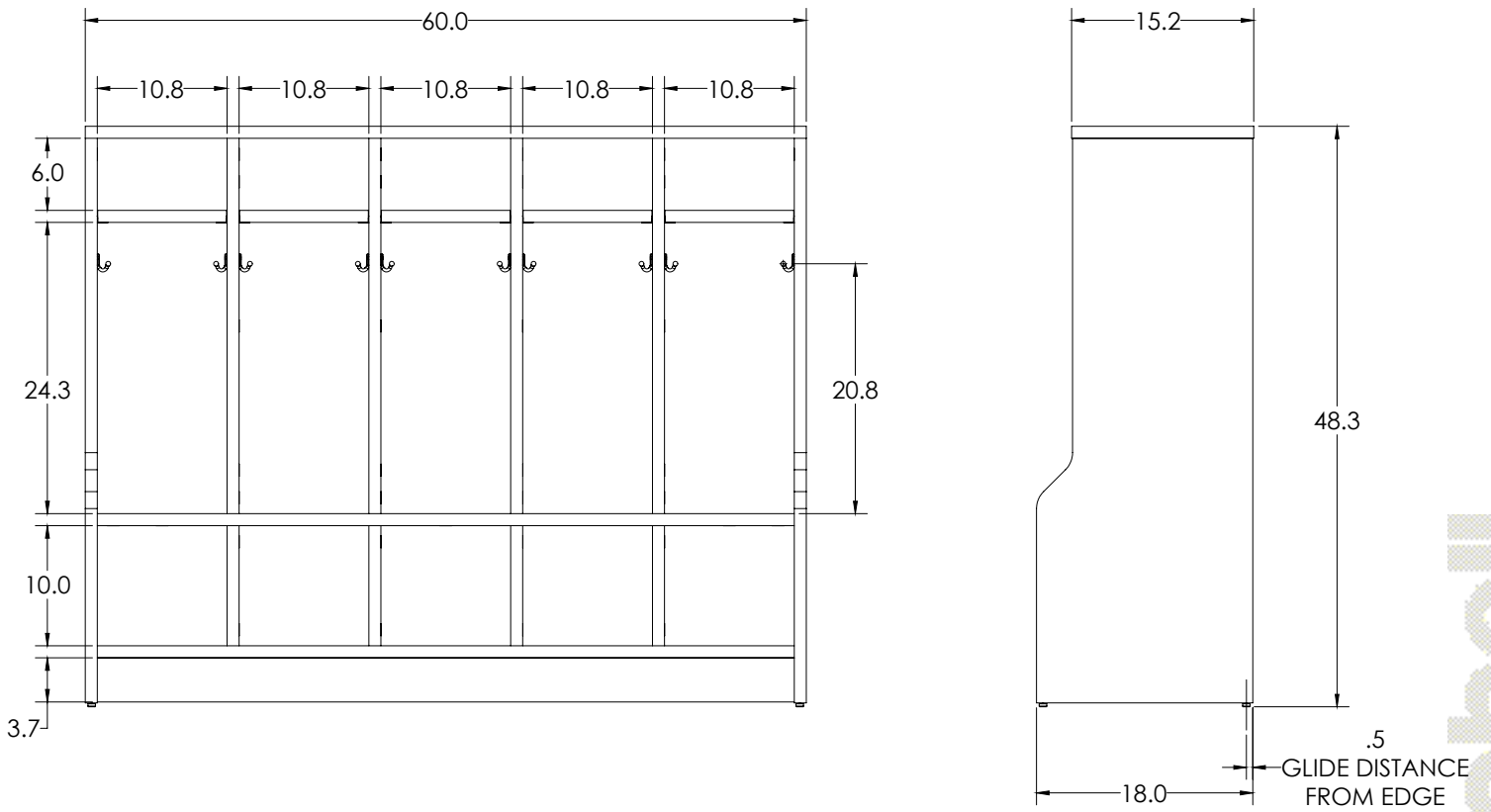

MODEL	DESCRIPTION	HEIGHT "	WIDTH "	DEPTH "
ASCL-6048	Single-Faced Open Coat Locker	48.3"	60.0"	18.0"

artcobell